

RoHS

IP66

HDMI
HIGH-DEFINITION MULTIMEDIA INTERFACE

REV.	DESCRIPTION	DATE
A	ISSUE	Sep/24/2015
A1	Correct pin assignment drawing	Oct/14/2015
B	Change plug length.	Aug/29/2016

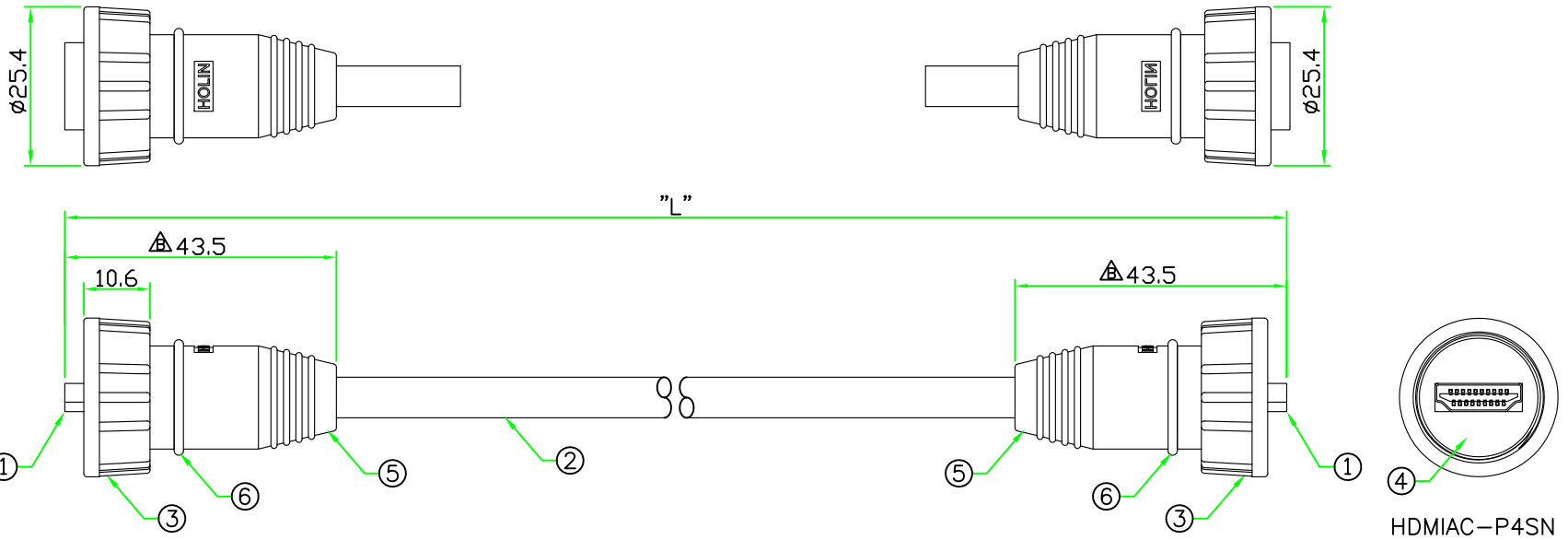

WIRING DIAGRAM

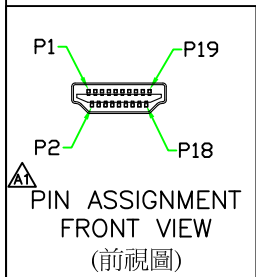

P/N	L
WHDMIAC-PA-2M	2000±100
WHDMIAC-PA-5M	5000±200

No.	PART NAME	DESCRIPTION	COLOR	Q'TY	REMARKS
6	O-RING	EPDM.	BLACK	2	
5	OVER MOLDED	PVC	BLACK	2	
4	GASKET	RUBBER	BLACK	2	
3	SCREW NUT	NYLON+GF.	BLACK	2	
2	CABLE	UL20276 (30AWGx1P+D)x5C + 30AWGx4C + Al/My+Braid OD: 6.5mm	BLACK		
1	CONNECTOR	HDMI A 19P Male solder connector. Gold flash.		2	

		TITLE : HDMI A Ttyp C Size Screw Type Molded Cable	
	UNIT: mm	P/N: WHDMIAC-PA-xxM	
SCALE	1:1	DR. JACK	
UNLESS OTHERWISE SPECIFIED TOLERANCES: .x ± 0.5 .xx ± 0.25 .xxx ± 0.1 ANGLE ± 1°		CH. ERIC	
REV. B	SHEET 1/1	DWG.NO: WHDMIAC-PA-xxM	
		AP.	