

RECOMMENDED
PANEL CUT OUT

RoHS

IP66~68

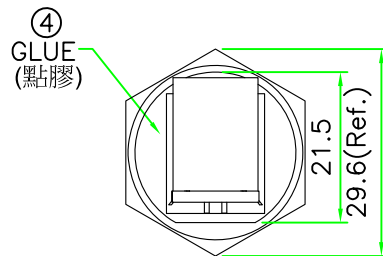
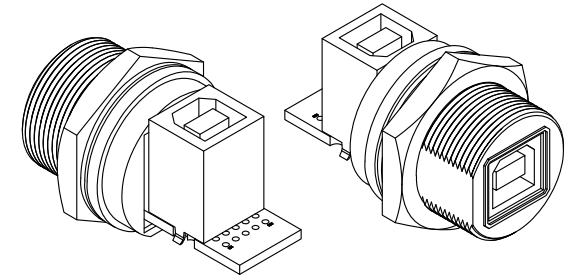
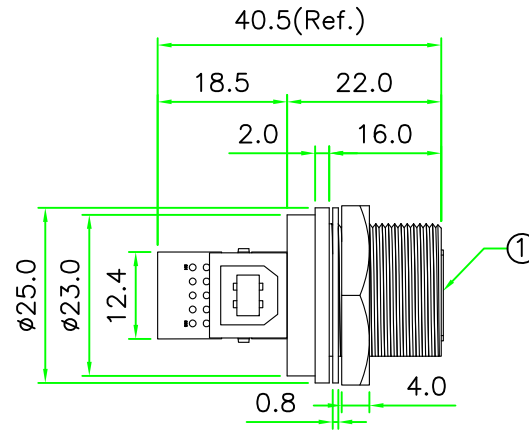

REAR VIEW
(後視圖)

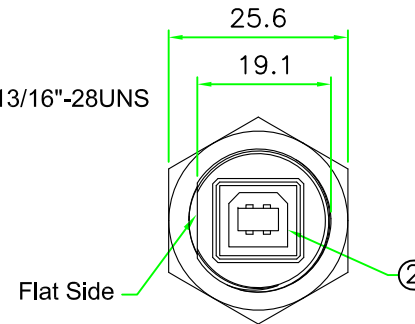
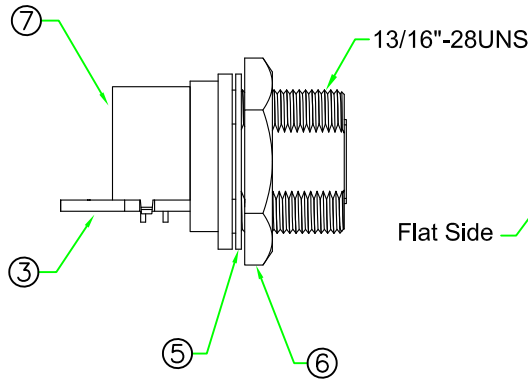

FRONT VIEW
(前視圖)

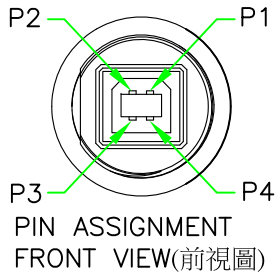

PIN ASSIGNMENT
FRONT VIEW(前視圖)

NOTES:

1. Current Rating: 1A
2. Connector Temperature Range: -25°C to 85°C
3. Contact Resistance: ≤30mΩ
4. Insulation Resistance: ≥100MΩ
5. Breakdown Voltage: ≥AC 500V/1 Minute
6. Panel Thickness Max. 6.0 mm

No.	PART NAME	DESCRIPTION	COLOR	Q'TY	REMARKS
7	CONNECTOR	USB 2.0 B Type Female Straight PCB Type.		1	
6	HEX NUT	NYLON+GF.	BLACK	1	
5	GASKET	EPDM.	BLACK	1	
4	GLUE	EPOXY.	BLACK	1	
3	PCB	FR4. Double Size, 1.6mm Thickness		1	
2	CONNECTOR	USB 2.0 B Type Female Connector.	WHITE	1	
1	BODY	USB B Type Female Connector Body. NYLON+GF.	BLACK	1	

UNIT: mm		TITLE : USB 2.0 B Type Female C Size Screw Type Circular Flange Panel With Straight Angle USB 2.0 B Type Female	P/N: USB2BC-P3CRJ	DR. SIBYL
SCALE	1:1			
REV. A	SHEET 1/1	DWG.NO: USB2BC-P3CRJ	AP.	