

RoHS

REV.	DESCRIPTION	DATE
A	ISSUE	Sep/08/2011
A1	Change part number.	Mar/06/2014
B	Change Design	Jun/17/2014

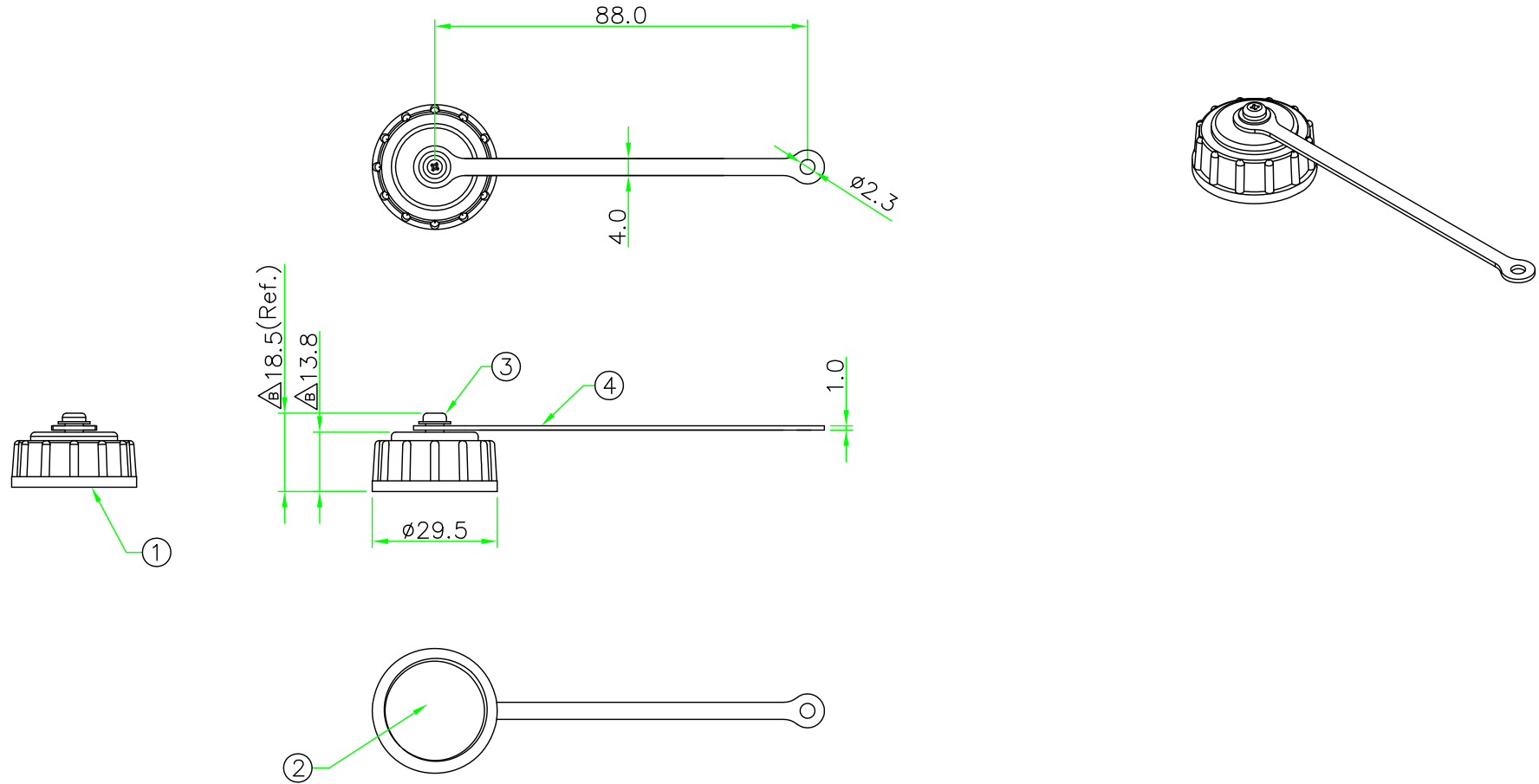

NOTE:
Panel Thickness Max. 2mm.

4	CHAIN	Plastic Rubber.	BLACK	1	59-135
3	SCREW	P ϕ /W=7.5 3x6 TP-1, SUS		1	
2	GASKET	Plastic Rubber.	BLACK	1	
1	CAP	Screw Type Cap, NYLON+GF.	BLACK	1	85-135-N2
No.	PART NAME	DESCRIPTION	COLOR	Q'TY	REMARKS

 <small>Votre partenaire électronique</small>	
 UNIT: mm SCALE 1:1.5 UNLESS OTHERWISE SPECIFIED TOLERANCES: .X ± 0.25 .XX ± 0.1 .XXX ± 0.05 ANGLE ± 1°X REV. B SHEET 1/1	TITLE : Waterproof Cap For D Size Male Connector Lock & Screw Type With Rubber Chain P/N:  CDX-WCAP-MC DWG.NO:  CDX-WCAP-MC
DR. Patty	CH. ERIC
AP.	