

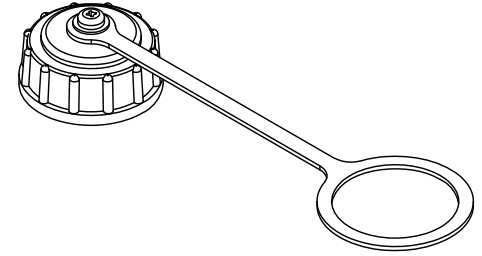

REV.	DESCRIPTION	DATE
A	ISSUE	Sep/08/2011
A1	Change part number.	Mar/06/2014
B	Change Design	Jun/17/2014

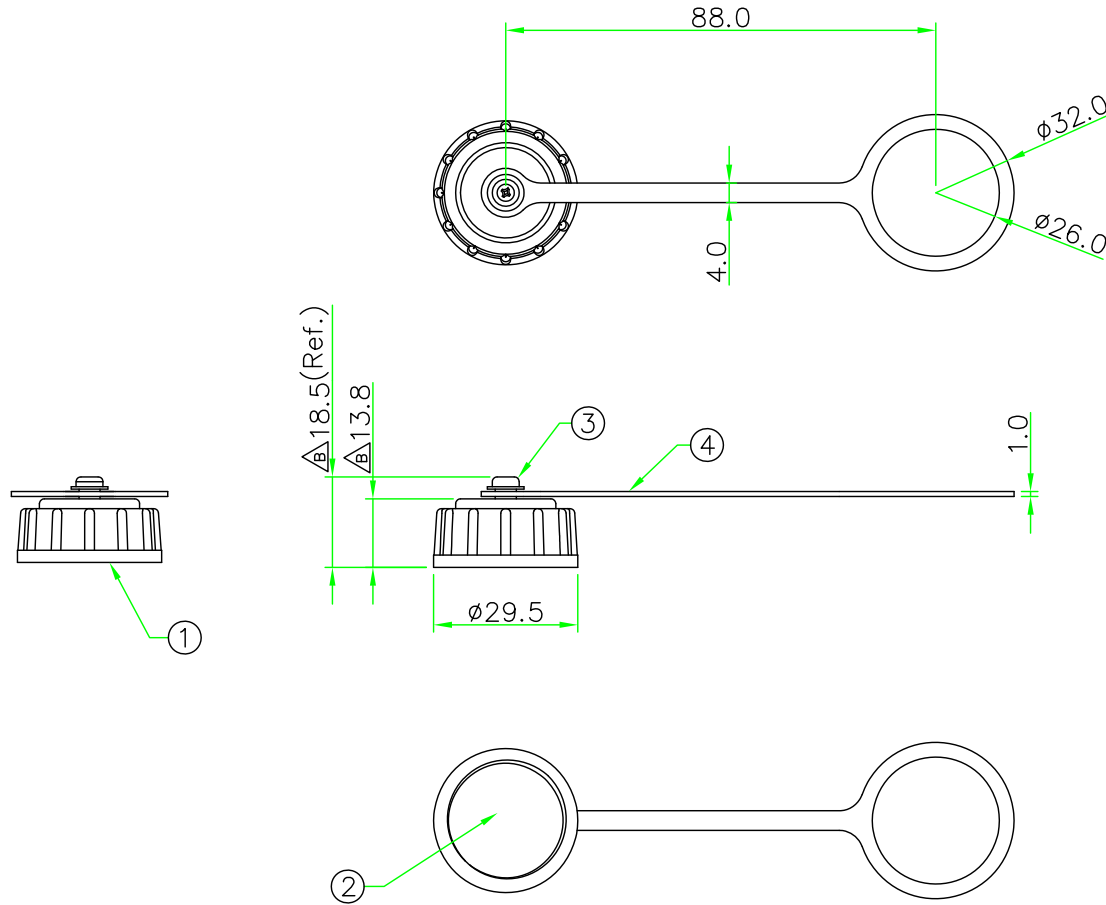

NOTE:  
Panel Thickness Max. 2mm.

4	CHAIN	Plastic Rubber.	BLACK	1	59-135-N2
3	SCREW	P $\phi$ /W=7.5 3x6 TP-1, SUS		1	
2	GASKET	Plastic Rubber.	BLACK	1	
1	CAP	Screw Type Cap, NYLON+GF.	BLACK	1	85-135-N2
No.	PART NAME	DESCRIPTION	COLOR	Q'TY	REMARKS

	
	UNIT: mm
SCALE	1:1.5
UNLESS OTHERWISE SPECIFIED TOLERANCES: .X ± 0.25 .XX ± 0.1 .XXX ± 0.05 ANGLE ± 1°X	
REV.	SHEET
B	1/1
TITLE : Waterproof Cap Screw Type For D Size Male Connector Lock & Screw Type With Rubber Chain	
P/N:  CDX-WCAP-MB	
DR. Patty CH. ERIC	
DWG.NO:  CDX-WCAP-MB	
AP.	