

# FEMALE HEADER DIP SINGLE ROW U-TYPE

## 24 SERIES - 1.27MM PITCH



Recommended P.C.B Layout (Top Side)  
(PCB BOARD TOLERANCE ±0.05)

### Specifications

- Rated Current: 1.0AMP
- Contact Resistance: 20mΩ Max
- Withstand Resistance: 500V AC/DC
- Insulation Resistance: 1000MΩ Min
- Operation Temperature: -40°C to +105°C
- Contact Material: Phosphore Bronze
- Contact Plating : Au Or Sn Over Ni
- Insulator Material : Polyester (UL94V-0)
- Standard : PA6T
- Max. Processing Temp : 230° for 30-60 seconds  
260° for 10 seconds

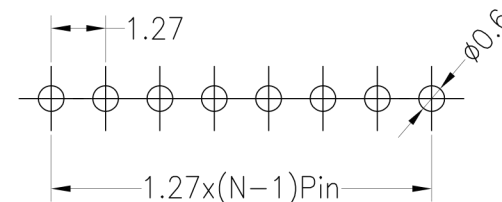

### Ordering Information

**2434D - 1 U (XX) - A B C (1)**

#### 1. Connector Series

#### 2. (H) Hauteur isolant

- H = 34 (Hauteur isolant : 3.4mm)

#### 3. U-Type

#### 4. Number of pins per row

#### 5. Insulator Material Option

- A = BK-PBT
- B = BK-PA66
- C = BK-PA6T
- D = BK-PA46
- E = BK-LCP

#### 6. Contact Plating

- A = Gold Flash
- B = 5U" Gold
- C = 10U" Gold
- D = 15U" Gold
- E = 30U" Gold
- F = Gold Flash/Tin
- G = Tin

#### 7. Post

- W (With Post)
- Ø (No Post)

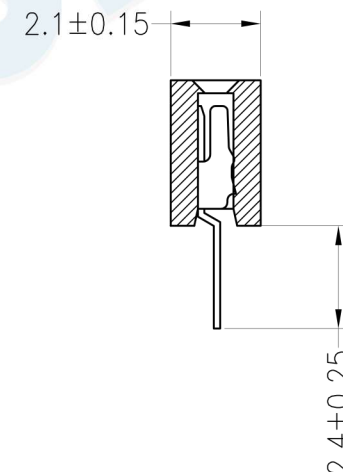
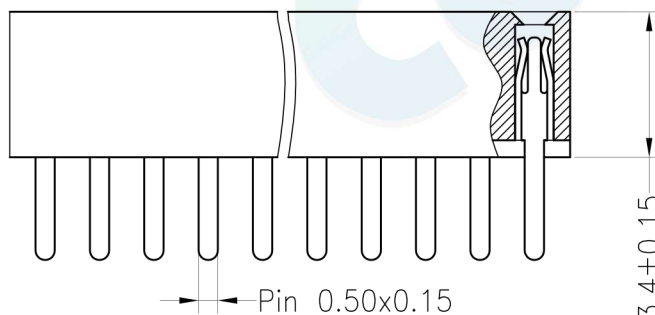
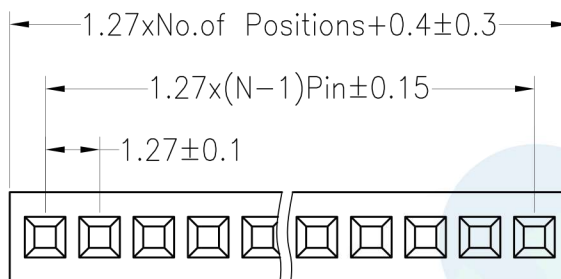
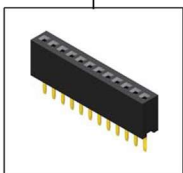

#### (1). Packaging

1=Tube 2=Tube+Cap 3=Reel+Cap 4=Reel+Mylar

|     |            |                          |  | OPERATION |       | DRAW    | BEN | 12.04.18 | SCALE | FIT | votre partenaire en électronique |                            |
|-----|------------|--------------------------|--|-----------|-------|---------|-----|----------|-------|-----|----------------------------------|----------------------------|
|     |            |                          |  | X.X       | ±0.30 |         |     |          |       |     |                                  |                            |
|     |            |                          |  | X.XX      | ±0.20 | CHECK   |     |          | SIZE  | A4  | PART NO.                         | 2434D - 1UXX - XXX         |
|     |            |                          |  | X.XXX     | ±0.10 |         |     |          |       |     |                                  |                            |
| A0  | 2012.04.18 | NEW DRAWING              |  | Angle     | ±3°   | APPROVE |     |          | SHEET | 1/1 | TITLE:                           | 1.27PF H3.40mm 1xNpin 180° |
| REV | DATE       | MODIFICATION DESCRIPTION |  | DIM       | TOL   |         |     |          |       |     |                                  |                            |

# FEMALE HEADER DIP SINGLE ROW U-TYPE

## 24 SERIES - 1.27MM PITCH



Recommended P.C.B Layout (Top Side)  
(PCB BOARD TOLERANCE ±0.05)

### Specifications

- Rated Current: 1.0AMP
- Contact Resistance: 20mΩ Max
- Withstand Resistance: 500V AC/DC
- Insulation Resistance: 1000MΩ Min
- Operation Temperature: -40°C to +105°C
- Contact Material: Phosphore Bronze
- Contact Plating : Au Over Ni
- Insulator Material : Polyester (UL94V-0)
- Standard : PA6T
- Max. Processing Temp : 230° for 30-60 seconds  
260° for 10 seconds

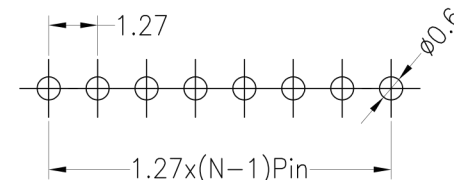

### Ordering Information

**2443D - 1 U (XX) - A B C (1)**

#### 1. Connector Series

#### 2. (H) Hauteur isolant

- H = 43 (Hauteur isolant : 4.3mm)

#### 3. U-Type

#### 4. Number of pins per row

#### 5. Insulator Material Option

- A = BK-PBT
- B = BK-PA66
- C = BK-PA6T
- D = BK-PA46
- E = BK-LCP

#### 6. Contact Plating

- A = Gold Flash
- B = 5U" Gold
- C = 10U" Gold
- D = 15U" Gold
- E = 30U" Gold
- F = Gold Flash/Tin
- G = Tin

#### 7. Post

- W (With Post)
- Ø (No Post)

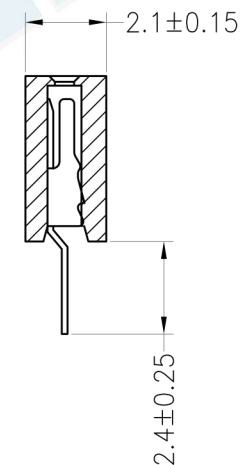
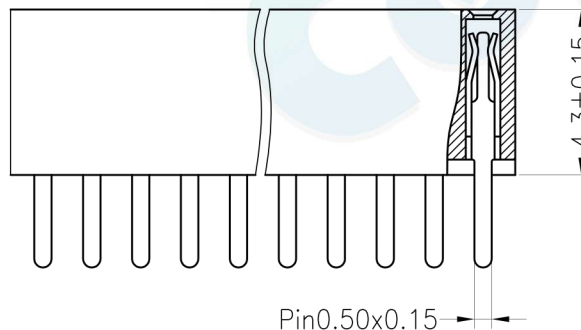
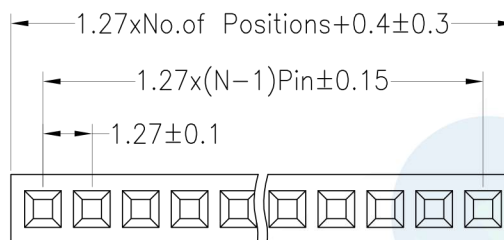
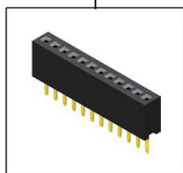

#### (1). Packaging

1=Tube 2=Tube+Cap 3=Reel+Cap 4=Reel+Mylar

|     |            |                          |        | OPERATION |       | DRAW    | BEN | 12.04.18 | SCALE | FIT | <br>votre partenaire en électronique |                         |
|-----|------------|--------------------------|--------|-----------|-------|---------|-----|----------|-------|-----|---|-------------------------|
|     |            |                          |        | X.X       | ±0.30 |         |     |          | UNIT  | mm  |   |                         |
|     |            |                          |        | X.XX      | ±0.20 | CHECK   |     |          | SIZE  | A4  | PART NO.  | 2443D - 1UXX - XXX      |
|     |            |                          |        | X.XXX     | ±0.10 |         |     |          | SHEET | 1/1 |   |                         |
| A0  | 2012.04.18 | NEW DRAWING              |        | Angle     | ±3°   | APPROVE |     |          | PROJ. | ◆   | TITLE:  | 1.27PF 1xNPin H4.3 180° |
| REV | DATE       | MODIFICATION DESCRIPTION | CHANGE | DIM       | TOL   |         |     |          |       |     |   |                         |