

# FEMALE HEADER DIP DUAL ROW U-TYPE SIDE ENTRY

## 24 SERIES - 1.27MM PITCH



Recommended P.C.B Layout (Top Side)  
(PCB BOARD TOLERANCE ±0.05)

### Specifications

- Rated Current: 1.0AMP
- Contact Resistance: 20mΩ Max
- Withstand Resistance: 500V AC/DC
- Insulation Resistance: 1000MΩ Min
- Operation Temperature: -40°C to +105°C
- Contact Material: Phosphore Bronze
- Contact Plating : Au Or Ni
- Insulator Material : Polyester (UL94V-0)
- Standard : PA6T
- Max. Processing Temp : 230° for 30-60 seconds  
260° for 10 seconds

### Ordering Information

**2435D - 2 U (XX) - A B C (1)**

1 2 3 4 5 6 7

#### 1. Connector Series

#### 2. (H) Hauteur isolant

- H = 35 (Hauteur isolant : 3.5mm)

#### 3. U-Type

#### 4. Number of pins per row

#### 5. Insulator Material Option

- A = BK-PBT
- B = BK-PA66
- C = BK-PA6T
- D = BK-PA46
- E = BK-LCP

#### 6. Contact Plating

- A = Gold Flash
- B = 5U" Gold
- C = 10U" Gold
- D = 15U" Gold
- E = 30U" Gold
- F = Gold Flash/Tin
- G = Tin

#### 7. Post

- W (With Post)
- Ø (No Post)

#### (1). Packaging

Ø=PE Bag 1=Tray 2=Tube 3=Tube+Cap 4=Reel+Cap 5=Reel+Mylar

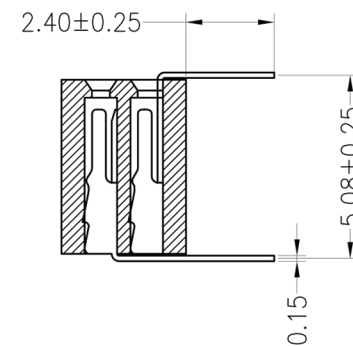
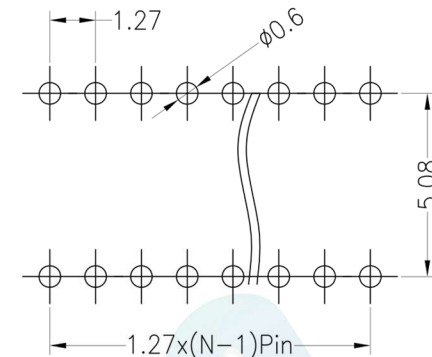
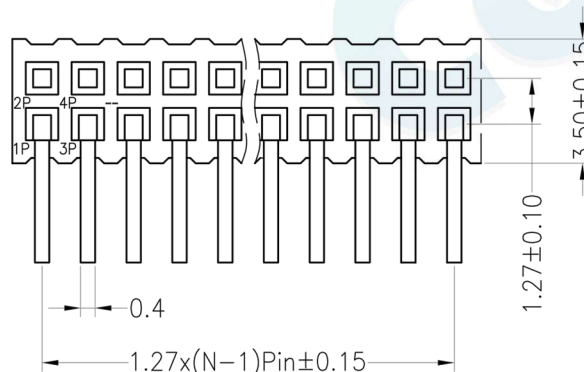
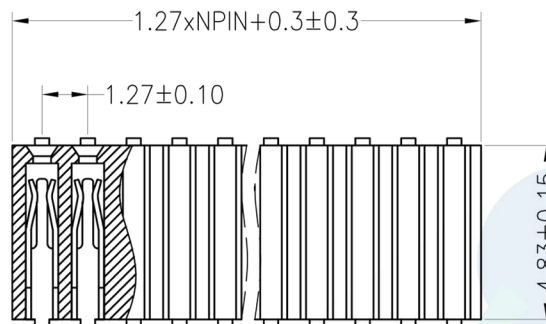
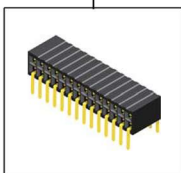

				OPERATION		DRAW	BEN	12.04.18	SCALE	FIT	 votre partenaire en électronique	
				X.X	±0.30							
				X.XX	±0.20	APPROVE			SIZE	A4	PART NO.	2435D - 2UXX - XXX
				Angle	±3°				SHEET	1/1		
REV	DATE	MODIFICATION DESCRIPTION	CHANGE	DIM	TOL			PROJ.				