

FEMALE HEADER SMT DUAL ROW Y-TYPE

23 SERIES - 2.00MM PITCH



Specifications

- Rated Current: 1.5AMP
- Contact Resistance: 20mΩ Max
- Withstand Resistance: 500V AC/DC
- Insulation Resistance: 1000MΩ Min
- Operation Temperature: -40°C to +105°C
- Contact Material: Brass
- Contact Plating : Au Or Sn Over Ni
- Insulator Material : Polyester (UL94V-0)
- Standard : PA6T
- Max. Processing Temp : 230° for 30-60 seconds
260° for 10 seconds

Ordering Information

2363S - 2 Y (XX) - A B C (1)

1 2 3 4 5 6 7

1. Connector Series

2. (H) Hauteur isolant

- H = 63 (Hauteur isolant : 6.35mm)

3. Y-Type

4. Number of pins per row

5. Insulator Material Option

- A = BK-PBT
- B = BK-PA66
- C = BK-PA6T
- D = BK-PA46
- E = BK-LCP

6. Contact Plating

- A = 1U" Gold
- B = 1.5U" Gold
- C = 2U" Gold
- D = 3U" Gold
- E = 5U" Gold
- F = 10U" Gold
- G = 15U" Gold
- H = Gold Flash/Tin
- I = Tin

7. Post

- W (With Post)
- Ø (No Post)

(1). Packaging

Ø=PE Bag 1=Tray 2=Tube 3=Tube+Cap 4=Reel+Cap 5=Reel+Mylar

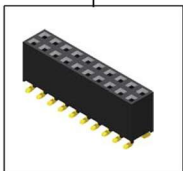

Recommended P.C.B Layout(Top Side)
(PCB BOARD TOLERANCE±0.05)

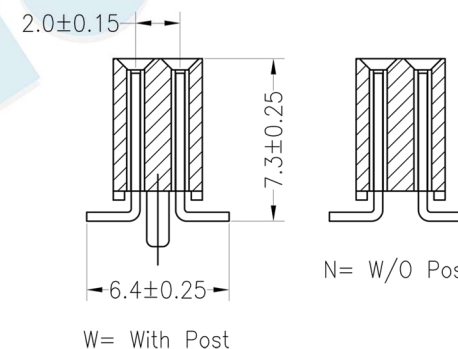
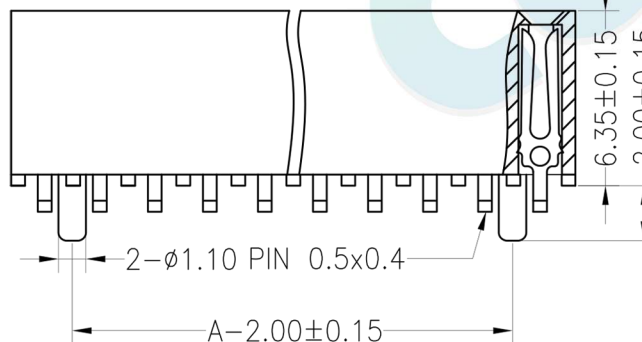
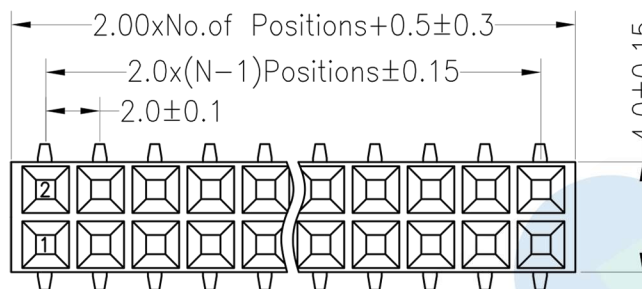
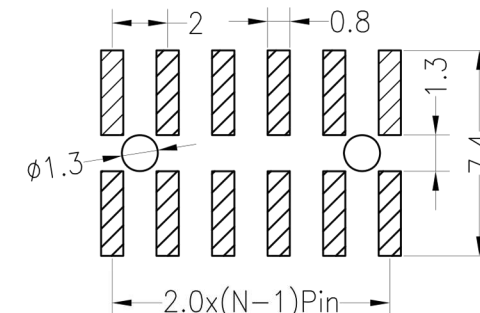

OPERATION		DRAW	BEN	12.04.18	SCALE	FIT
X.X	±0.30					
X.XX	±0.20	CHECK			UNIT	mm
X.XXX	±0.10					
Angle	±3°	APPROVE			SIZE	A4
DIM	TOL					
		PROJ.			SHEET	1/1



A0	2012.04.18	NEW DRAWING	
REV	DATE	MODIFICATION DESCRIPTION	CHANGE

PART NO.	2363S - 2YXX - XXX
TITLE:	2.00PF H6.35mm 2xNpin SMT