

FEMALE HEADER DIP DUAL ROW U-TYPE

22 SERIES - 2.54MM PITCH



Specifications

- Rated Current: 3.0AMP
- Contact Resistance: 20mΩ Max
- Withstand Resistance: 1000V AC/DC
- Insulation Resistance: 1000MΩ Min
- Operation Temperature: -40°C to +105°C
- Contact Material: Brass
- Contact Plating : Au Or Sn Over Ni
- Insulator Material : Polyester (UL94V-0)
- Standard : PA6T
- Max. Processing Temp : 230° for 30-60 seconds
260° for 10 seconds

Recommended P.C.B Layout(Top Side)
(PCB BOARD TOLERANCE±0.05)

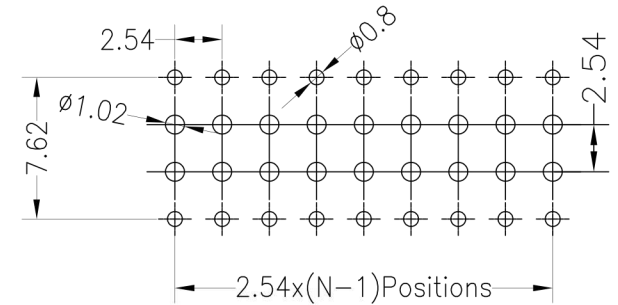

Ordering Information

2235D - 2 U (XX) - A B C (1) 01*

1. Connector Series

2. (H) Hauteur isolant

- H = 35 (Hauteur isolant : 3.5mm)

3. U-Type

4. Number of pins per row

5. Insulator Material Option

- A = BK-PBT
- B = BK-PA66
- C = BK-PA6T
- D = BK-PA46
- E = BK-PA9T
- F = BK-LCP

6. Contact Plating

- A = Gold Flash
- B = 1.5U" Gold
- C = 2U" Gold
- D = 3U" Gold
- E = 5U" Gold
- F = Gold Flash/Tin
- G = Tin

7. Post

- W (With Post)
- Ø (No Post)

(01)* = Type 1

(1). Packaging

Ø=PE Bag 1=Tray 2=Tube 3=Tube+Cap 4=Reel+Cap 5=Reel+Mylar

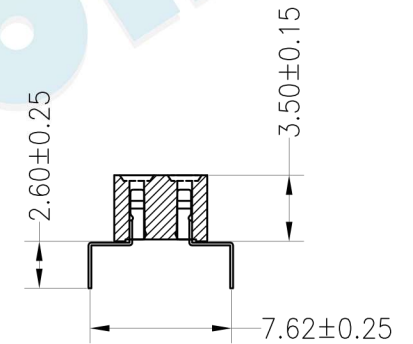
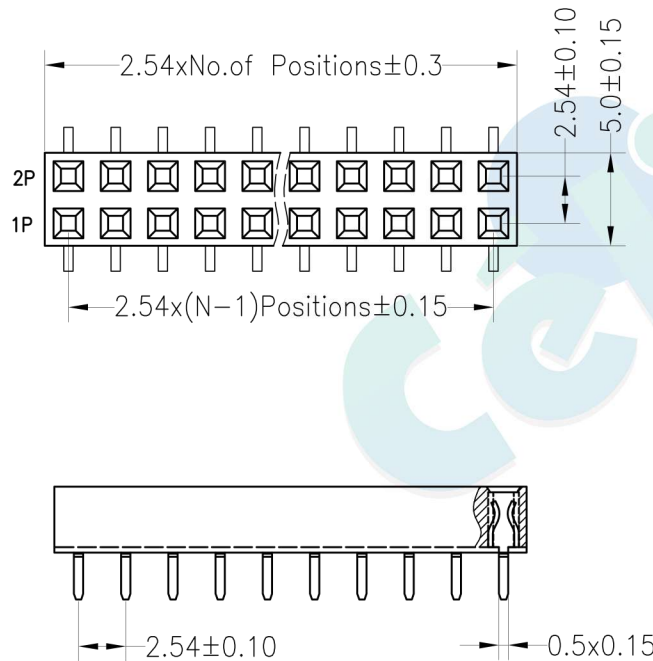
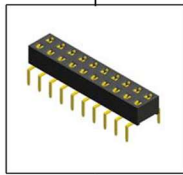

				OPERATION		DRAW	BEN	12.04.18	SCALE	FIT	 votre partenaire en électronique	
				X.X	±0.30				UNIT	mm		
				X.XX	±0.20	CHECK			SIZE	A4	PART NO.	2235D - 2UXX - XXX 01
				X.XXX	±0.10				SHEET	1/1		
A0	2012.04.18	NEW DRAWING		Angle	±3°	APPROVE			PROJ.	◆	TITLE:	2.54PF H3.5mm 2xNpin W5.0mm
REV	DATE	MODIFICATION DESCRIPTION	CHANGE	DIM	TOL							

FEMALE HEADER DIP DUAL ROW U-TYPE

22 SERIES - 2.54MM PITCH



Specifications

- Rated Current: 3.0AMP
- Contact Resistance: 20mΩ Max
- Withstand Resistance: 1000V AC/DC
- Insulation Resistance: 1000MΩ Min
- Operation Temperature: -40°C to +105°C
- Contact Material: Phosphore Bronze
- Contact Plating : Au Or Sn Over Ni
- Insulator Material : Polyester (UL94V-0)
- Standard : PA6T
- Max. Processing Temp : 230° for 30-60 seconds
260° for 10 seconds

Recommended P.C.B Layout(Top Side)
(PCB BOARD TOLERANCE±0.05)

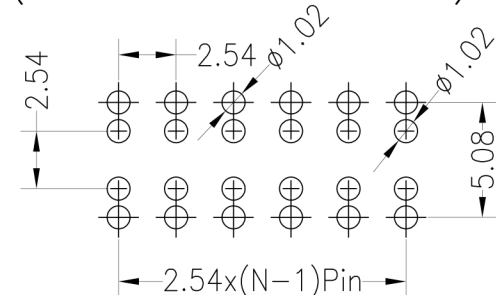

Ordering Information

2245D - 2 U (XX) - A B C (1) 02*

1 2 3 4 5 6 7

1. Connector Series

2. (H) Hauteur isolant

- H = 45 (Hauteur isolant : 4.5mm)

3. U-Type

4. Number of pins per row

5. Insulator Material Option

- A = BK-PBT
- B = BK-PA66
- C = BK-PA6T
- D =BK-PA46
- E =BK-PA9T
- F =BK-LCP

6. Contact Plating

- A = Gold Flash
- B = 3U" Gold
- C = 5U" Gold
- D = 10U" Gold
- E= 15U" Gold
- F= 30U" Gold
- G=Gold Flash/Tin
- H= Tin

7. Post

- W (With Post)
- Ø (No Post)

(02)* = Type 2

(1). Packaging

Ø=PE Bag 1=Tray 2=Tube 3=Tube+Cap 4=Reel+Cap 5=Reel+Mylar

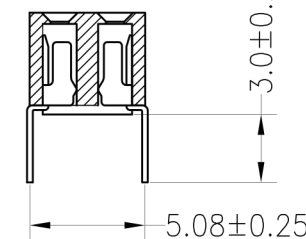
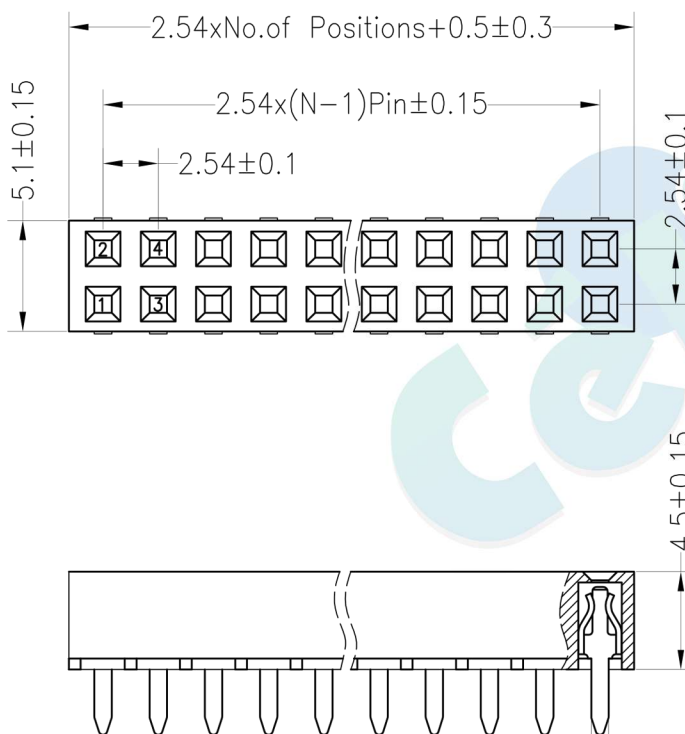
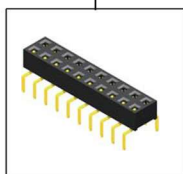

0.8x0.25

				OPERATION		DRAW	BEN	12.04.18	SCALE	FIT	 votre partenaire en électronique	
				X.X	±0.30				UNIT	mm		
				X.XX	±0.20	CHECK			SIZE	A4	PART NO.	2245D - 2UXX - XXX 02
				X.XXX	±0.10				SHEET	1/1		
A0	2012.04.18	NEW DRAWING		Angle	±3°	APPROVE			PROJ.	◆	TITLE:	2.54PF H4.5mm 2xNpin SMT W5.10 Bottom Entry
REV	DATE	MODIFICATION DESCRIPTION		DIM	TOL							

FEMALE HEADER DIP DUAL ROW U-TYPE

22 SERIES - 2.54MM PITCH



Recommended P.C.B Layout (Top Side)
(PCB BOARD TOLERANCE ±0.05)

Specifications

- Rated Current: 3.0AMP
- Contact Resistance: 20mΩ Max
- Withstand Resistance: 1000V AC/DC
- Insulation Resistance: 1000MΩ Min
- Operation Temperature: -40°C to +105°C
- Contact Material: Brass
- Contact Plating : Au Or Sn Over Ni
- Insulator Material : Polyester (UL94V-0)
- Standard : PA6T
- Max. Processing Temp : 230° for 30-60 seconds
260° for 10 seconds

Ordering Information

2250D - 2 U (XX) - A B C (1) 0X*

1 2 3 4 5 6 7

1. Connector Series

2. (H) Hauteur isolant

- H = 50 (Hauteur isolant : 5.0mm)

3. U-Type

4. Number of pins per row

5. Insulator Material Option

- A = BK-PBT
- B = BK-PA66
- C = BK-PA6T
- D = BK-PA46
- E = BK-LCP

6. Contact Plating

- A = Gold Flash
- B = 5U" Gold
- C = 10U" Gold
- D = 15U" Gold
- E = 30U" Gold
- F = Gold Flash/Tin
- G = Tin

7. Post

- W (With Post)
- Ø (No Post)

(01)* = Type 1

(02)* = Type 2

(1). Packaging

Ø=PE Bag 1=Tray 2=Tube 3=Tube+Cap 4=Reel+Cap 5=Reel+Mylar

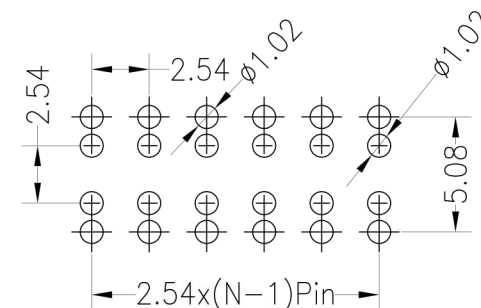
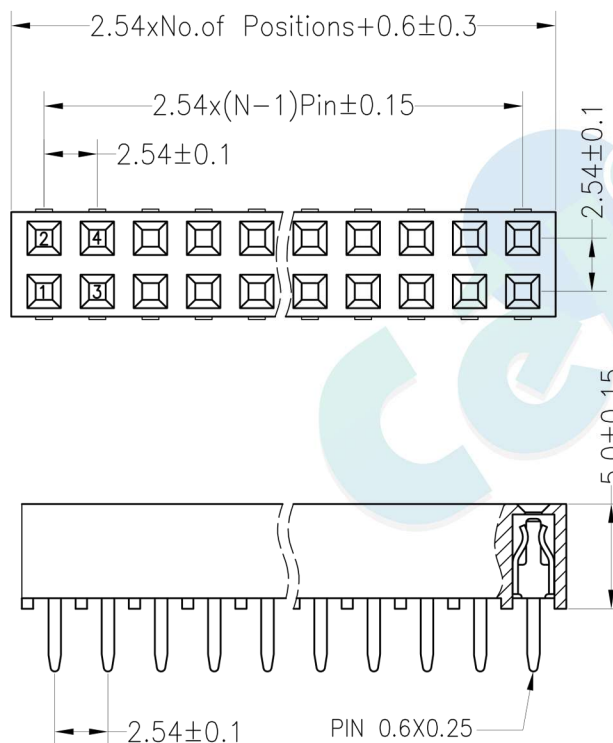
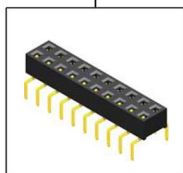

Type 1

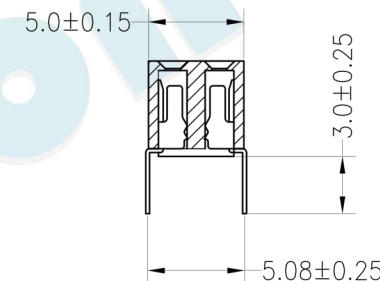

Type 2

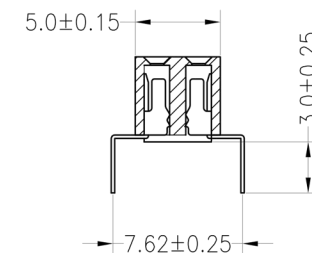

				OPERATION		DRAW	BEN	12.04.18	SCALE	FIT	 votre partenaire en électronique	
				X.X	±0.30				UNIT	mm		
				X.XX	±0.20	CHECK			SIZE	A4	PART NO.	2250D - 2UXX - XXX 0X
				X.XXX	±0.10				SHEET	1/1	TITLE:	2.54PF H5.0mm 2xNpin SMT W5.00 Bottom Entry
REV	DATE	MODIFICATION DESCRIPTION	CHANGE	DIM	TOL	APPROVE			PROJ.			

FEMALE HEADER DIP DUAL ROW U-TYPE

22 SERIES - 2.54MM PITCH



Recommended P.C.B Layout (Top Side)
(PCB BOARD TOLERANCE ±0.05)

Specifications

- Rated Current: 3.0AMP
- Contact Resistance: 20mΩ Max
- Withstand Resistance: 1000V AC/DC
- Insulation Resistance: 1000MΩ Min
- Operation Temperature: -40°C to +105°C
- Contact Material: Phosphore Bronze
- Contact Plating : Au Or Sn Over Ni
- Insulator Material : Polyester (UL94V-0)
- Standard : PA6T
- Max. Processing Temp : 230° for 30-60 seconds
260° for 10 seconds

Ordering Information

2250D - 2 U (XX) - A B C (1) 03*

1 2 3 4 5 6 7

1. Connector Series

2. (H) Hauteur isolant

- H = 50 (Hauteur isolant : 5.0mm)

3. U-Type

4. Number of pins per row

5. Insulator Material Option

- A = BK-PBT
- B = BK-PA66
- C = BK-PA6T
- D = BK-PA46
- E = BK-PA9T
- F = BK-LCP

6. Contact Plating

- A = Gold Flash
- B = 1.5U" Gold
- C = 2U" Gold
- D = 3U" Gold
- E = 5U" Gold
- F = Gold Flash/Tin
- G = Tin

7. Post

- W (With Post)
- Ø (No Post)

(03)* = Type 3

(1). Packaging

Ø=PE Bag 1=Tray 2=Tube 3=Pe 4=Tape&Reel 5=Tube&Reel

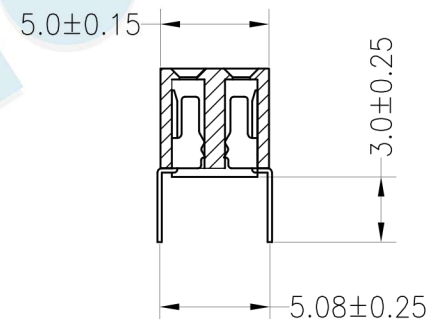
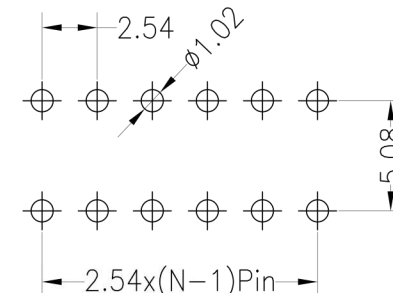
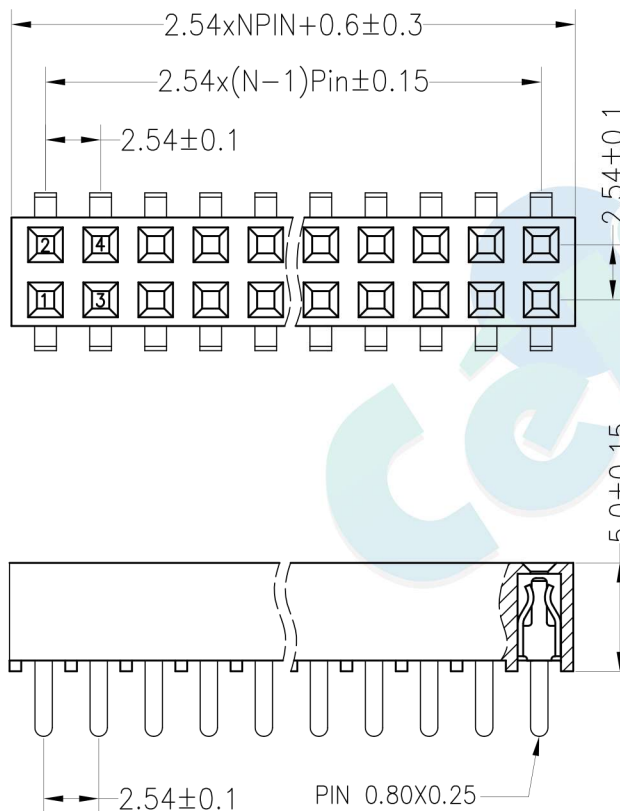
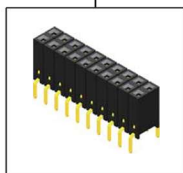

				OPERATION		DRAW	BEN	12.04.18	SCALE	FIT	 votre partenaire en électronique	
				X.X	±0.30				UNIT	mm		
				X.XX	±0.20	CHECK			SIZE	A4	PART NO.	2250D - 2UXX - XXX 03
				X.XXX	±0.10				SHEET	1/1		
A0	2012.04.18	NEW DRAWING		Angle	±3°	APPROVE			PROJ.		TITLE:	2.54PF H5.0mm 2xNpin SMT W5.00 Bottom Entry
REV	DATE	MODIFICATION DESCRIPTION		DIM	TOL							