

# FEMALE HEADER SMT DUAL ROW O-TYPE

## 22 SERIES - 2.54MM PITCH



### Specifications

- Rated Current: 3.0AMP
- Contact Resistance: 20mΩ Max
- Withstand Resistance: 1000V AC/DC
- Insulation Resistance: 1000MΩ Min
- Operation Temperature: -40°C to +105°C
- Contact Material: Brass
- Contact Plating : Au Or Sn Over Ni
- Insulator Material : Polyester (UL94V-0)
- Standard : PA6T
- Max. Processing Temp : 230° for 30-60 seconds  
260° for 10 seconds

Recommended P.C.B Layout(Top Side)  
(PCB BOARD TOLERANCE±0.05)

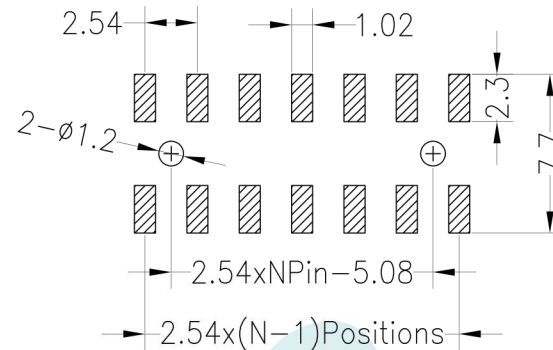

### Ordering Information

**2271S - 2 O (XX) - A B C (1)**

#### 1. Connector Series

#### 2. (H) Hauteur isolant

- H = 71 (Hauteur isolant : 7.1mm)

#### 3. O-Type

#### 4. Number of pins per row

#### 5. Insulator Material Option

- A = BK-PBT
- B = BK-PA66
- C = BK-PA6T
- D = BK-PA46
- E = BK-PA9T
- F = BK-LCP

#### 6. Contact Plating

- A = Gold Flash
- B = 3U" Gold
- C = 5U" Gold
- D = 10U" Gold
- E = 15U" Gold
- F = 30U" Gold
- G = Gold Flash/Tin
- H = Tin

#### 7. Post

- W (With Post)
- Ø (No Post)

#### (1). Packaging

Ø=PE Bag 1=Tray 2=Tube 3=Tube+Cap 4=Reel+Cap 5=Reel+Mylar

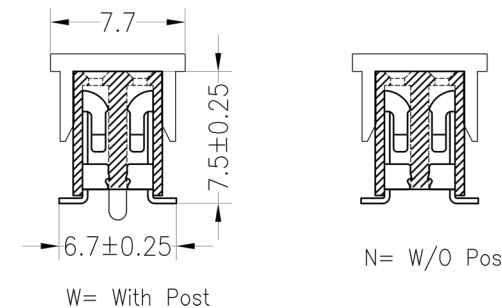
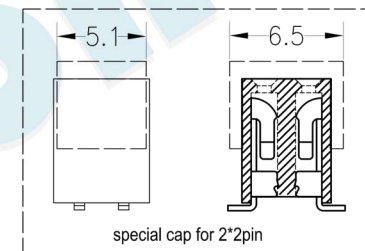
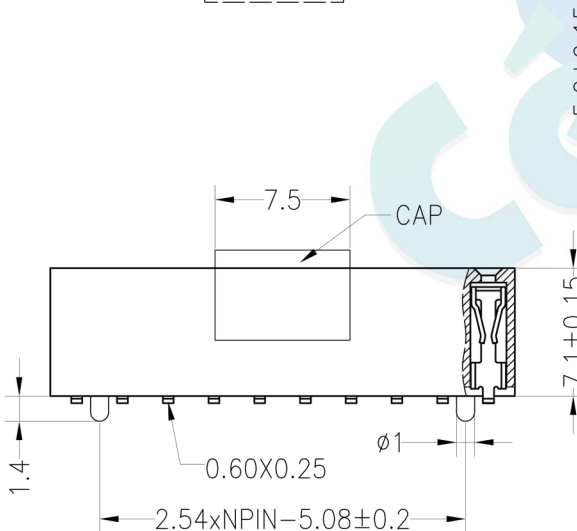
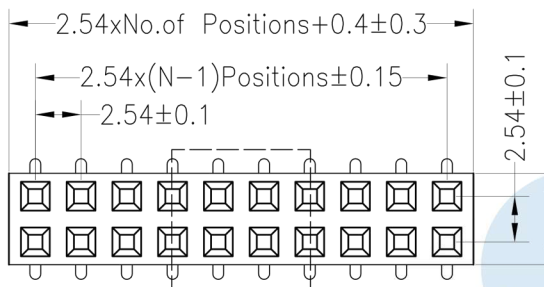
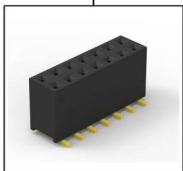

				OPERATION		DRAW	BEN	12.04.18	SCALE	FIT	votre partenaire en électronique	
				X.X	±0.30							
A0	2012.04.18	NEW DRAWING		X.XX	±0.20	APPROVE			SHEET	1/1	TITLE:	2.54PF H7.1mm 2xNpin SMT O-Type
REV	DATE	MODIFICATION DESCRIPTION	CHANGE	Angle	±3°							

# FEMALE HEADER SMT DUAL ROW U-TYPE

## 22 SERIES - 2.54MM PITCH



### Specifications

- Rated Current: 3.0AMP
- Contact Resistance: 20mΩ Max
- Withstand Resistance: 1000V AC/DC
- Insulation Resistance: 1000MΩ Min
- Operation Temperature: -40°C to +105°C
- Contact Material: Brass
- Contact Plating : Au Or Sn Over Ni
- Insulator Material : Polyester (UL94V-0)
- Standard : PA6T
- Max. Processing Temp : 230° for 30-60 seconds  
260° for 10 seconds

### Ordering Information

**2271S - 2 U (XX) - A B C (1) 01\***

1 2 3 4 5 6 7

#### 1. Connector Series

#### 2. (H) Hauteur isolant

- H = 71 (Hauteur isolant : 7.1mm)

#### 3. U-Type

#### 4. Number of pins per row

#### 5. Insulator Material Option

- A = BK-PBT
- B = BK-PA66
- C = BK-PA6T
- D = BK-PA46
- E = BK-LCP

#### 6. Contact Plating

- A = Gold Flash
- B = 5U" Gold
- C = 10U" Gold
- D = 15U" Gold
- E = 30U" Gold
- F = Gold Flash/Tin
- G = Tin

#### 7. Post

- W (With Post)
- Ø (No Post)

(01)\* = Type 1

(1). Packaging

Ø=PE Bag 1=Tray 2=Tube 3=Tube+Cap 4=Reel+Cap 5=Reel+Mylar

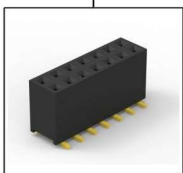

Recommended P.C.B Layout (Top Side)  
(PCB BOARD TOLERANCE ±0.05)

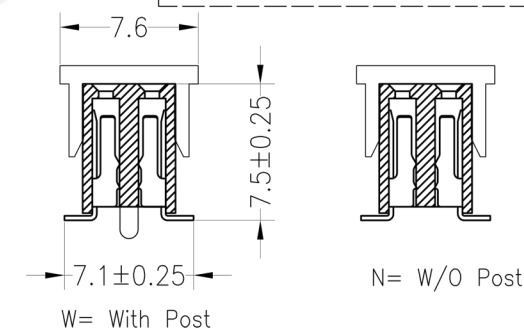
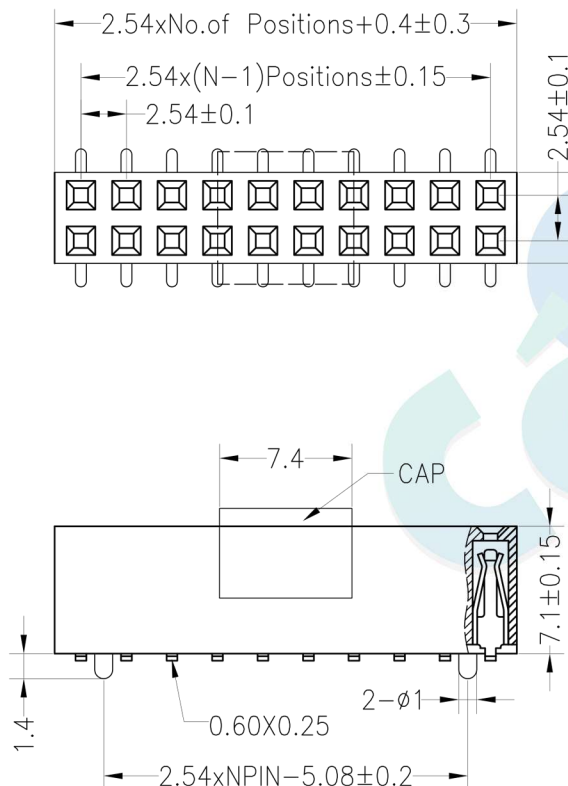
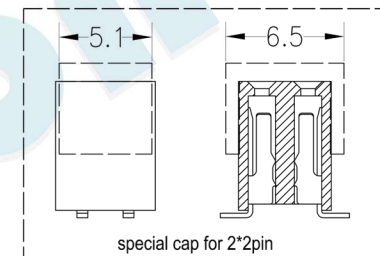
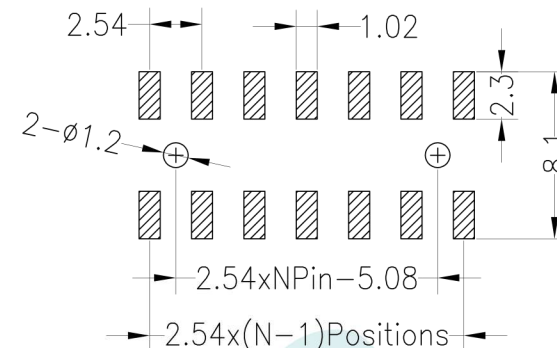

				OPERATION		DRAW	BEN	12.04.18	SCALE	FIT	 votre partenaire en électronique	
				X.X	±0.30				UNIT	mm		
				X.XX	±0.20	CHECK			SIZE	A4	PART NO.	2271S - 2UXX - XXX 01
				X.XXX	±0.10	APPROVE			SHEET	1/1	TITLE:	2.54PF H7.1mm 2xNpin SMT
REV	DATE	MODIFICATION DESCRIPTION	CHANGE	Angle	±3°		DIM	TOL	PROJ.			

# FEMALE HEADER SMT DUAL ROW U-TYPE

## 22 SERIES - 2.54MM PITCH



### Specifications

- Rated Current: 3.0AMP
- Contact Resistance: 20mΩ Max
- Withstand Resistance: 1000V AC/DC
- Insulation Resistance: 1000MΩ Min
- Operation Temperature: -40°C to +105°C
- Contact Material: Brass
- Contact Plating : Au Or Sn Over Ni
- Insulator Material : Polyester (UL94V-0)
- Standard : PA6T
- Max. Processing Temp : 230° for 30-60 seconds  
260° for 10 seconds

### Ordering Information

**2271S - 2 U (XX) - A B C (1) 02\***

1 2 3 4 5 6 7

#### 1. Connector Series

#### 2. (H) Hauteur isolant

- H = 71 (Hauteur isolant : 7.1mm)

#### 3. U-Type

#### 4. Number of pins per row

#### 5. Insulator Material Option

- A = BK-PBT
- B = BK-PA66
- C = BK-PA6T
- D = BK-PA46
- E = BK-PA9T
- F = BK-LCP

#### 6. Contact Plating

- A = 1U" Gold
- B = 1.5U" Gold
- C = 2U" Gold
- D = 3U" Gold
- E = Gold Flash/Tin
- F = Tin

#### 7. Post

- W (With Post)
- Ø (No Post)

(02)\* = Type 2

(1). Packaging

Ø=PE Bag 1=Tray 2=Tube 3=Tube+Cap 4=Reel+Cap 5=Reel+Mylar

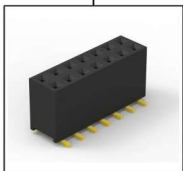

Recommended P.C.B Layout (Top Side)  
(PCB BOARD TOLERANCE ±0.05)

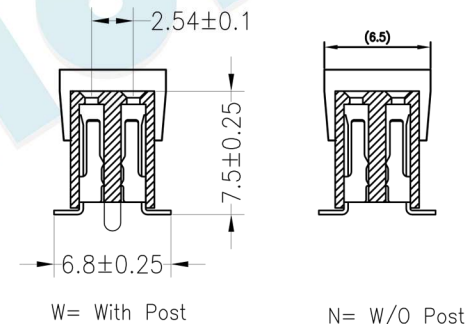
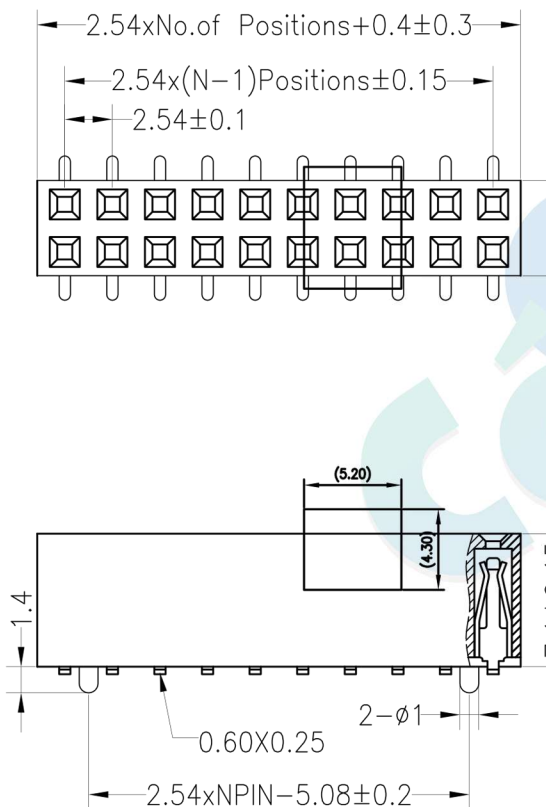
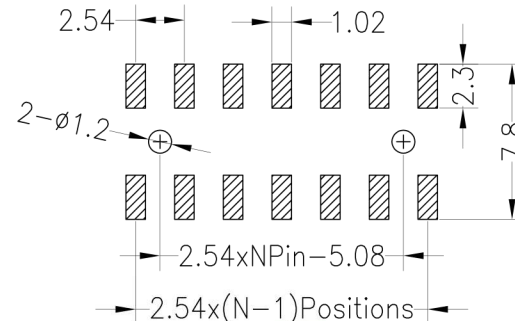

				OPERATION		DRAW	BEN	12.04.18	SCALE	FIT	 votre partenaire en électronique	
				X.X	±0.30				UNIT	mm		
				X.XX	±0.20	CHECK			SIZE	A4	PART NO.	2271S - 2UXX - XXX 02
				X.XXX	±0.10				SHEET	1/1		
A0	2012.04.18	NEW DRAWING		Angle	±3°	APPROVE			PROJ.	◆	TITLE:	2.54PF H7.1mm 2xNpin SMT
REV	DATE	MODIFICATION DESCRIPTION	CHANGE	DIM	TOL							

# FEMALE HEADER SMT DUAL ROW U-TYPE

## 22 SERIES - 2.54MM PITCH



### Specifications

- Rated Current: 3.0AMP
- Contact Resistance: 20mΩ Max
- Withstand Resistance: 1000V AC/DC
- Insulation Resistance: 1000MΩ Min
- Operation Temperature: -40°C to +105°C
- Contact Material: Brass
- Contact Plating : Au Or Sn Over Ni
- Insulator Material : Polyester (UL94V-0)
- Standard : PA6T
- Max. Processing Temp : 230° for 30-60 seconds  
260° for 10 seconds

### Ordering Information

**2271S - 2 U (XX) - A B C (1) 03\***

1 2 3 4 5 6 7

#### 1. Connector Series

#### 2. (H) Hauteur isolant

- H = 71 (Hauteur isolant : 7.1mm)

#### 3. U-Type

#### 4. Number of pins per row

#### 5. Insulator Material Option

- A = BK-PBT
- B = BK-PA66
- C = BK-PA6T
- D = BK-PA46
- E = BK-PA9T
- F = BK-LCP

#### 6. Contact Plating

- A = 1U" Gold
- B = 1.5U" Gold
- C = 2U" Gold
- D = 3U" Gold
- E = Gold Flash/Tin
- F = Tin

#### 7. Post

- W (With Post)
- Ø (No Post)

(03)\* = Type 3

(1). Packaging

Ø=PE Bag 1=Tray 2=Tube 3=Tube+Cap 4=Reel+Cap 5=Reel+Mylar

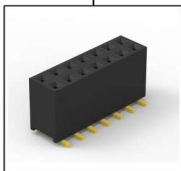

Recommended P.C.B Layout (Top Side)  
(PCB BOARD TOLERANCE ±0.05)

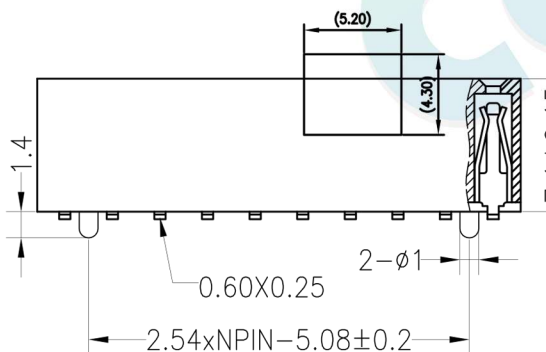
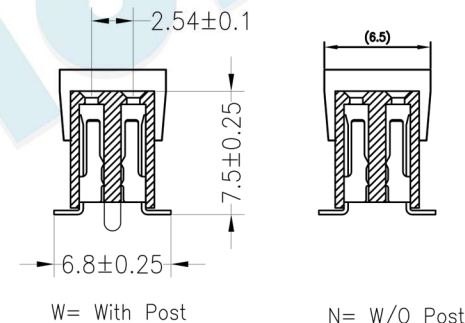
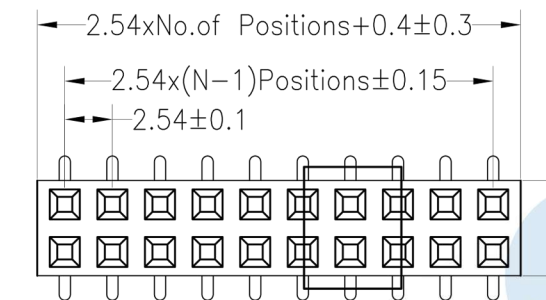
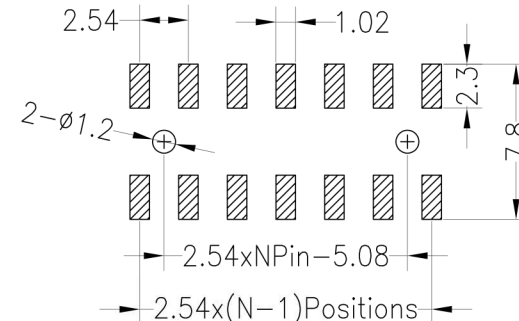

				OPERATION		DRAW	BEN	12.04.18	SCALE	FIT	 votre partenaire en électronique		
				X.X	±0.30				UNIT	mm			
				X.XX	±0.20	CHECK		SIZE	A4	PART NO.			2271S - 2UXX - XXX 03
				X.XXX	±0.10	APPROVE		SHEET	1/1	TITLE:			2.54PF H7.1mm 2xNpin SMT
REV	DATE	MODIFICATION DESCRIPTION	CHANGE	DIM	TOL				PROJ.				