

p.c.b. layout

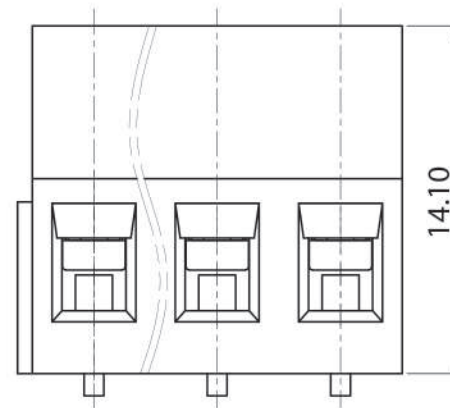

Approvals

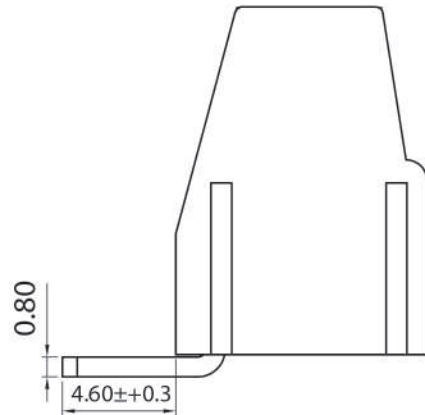
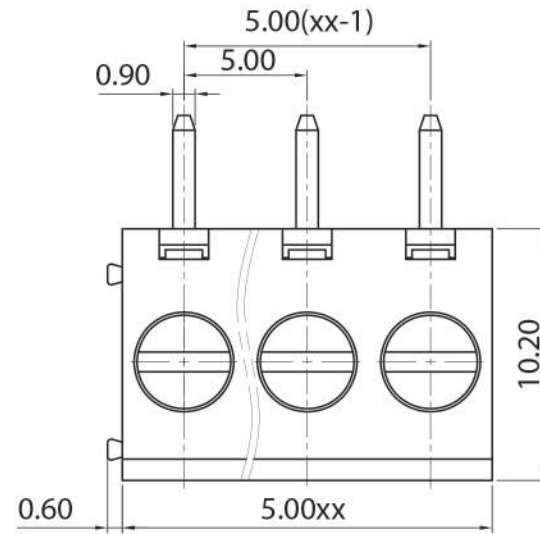

16A-300V

20A-250V

Electrical

Rated voltage 250V
 Rated current 20A
 Contact resistance 20mΩ
 Insulation resistance 500MΩ/DC500V
 Withstanding voltage AC2000V/1min
 Wire range 22-12 AWG 2,5mm²

Torque 0,4Nm (3.6Lb in)
 Temp. Range -40°C +105°C
 Stripping lenght 6 mm
 Max sold. time +250°C for 5 sec.

Dimensions

Pitch 5 mm
 Poles 2÷24

Material

Housing PA66 UL94V0
 Pin Copper Alloy, Sn plated
 Cage Copper Alloy, Ni plated
 Screws M2,5 steel, Zn plated
 Side Block
 Nut screw
 Clamp

General description of ordering code

Series	n. Poles	Pitch	Version	Color	Custom
MRS52	2÷24	-5	-H		

Version Date

2020/01

07/04/2020