

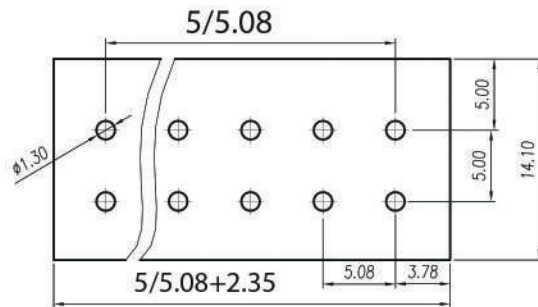

CÉLION

product specification



P.C.B. LAYOUT

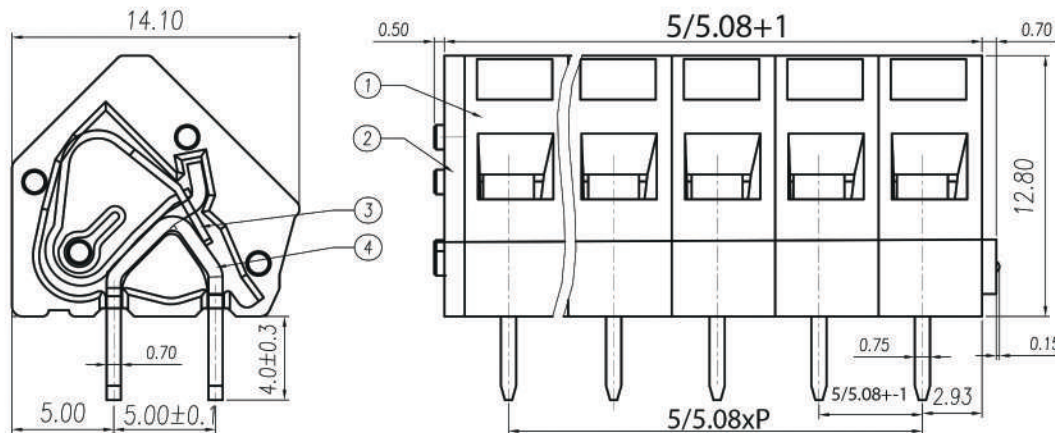

Approvals

UL-cUL not approved
VDE not approved

Electrical

Standard
Rated voltage 250V
Rated current 15A
Contact resistance 20mΩ
Insulation resistance 500MΩ/DC500V
Withstanding voltage AC2000V / 1min
Wire range 1.5mmq 26÷16 AWG

Torque
Temp. Range -40°C + 105°C
Stripping length 5mm
Max sold. time +250°C for 5 sec

Dimensions

Pitch 5/5.08
Poles 1÷24

Material

Housing PA66 UL 94V0
Pin Copper Alloy, tin plated
Cage Stainless Steel
Screws
Slide Block
Nut screw
Clamp

Version/Version

Date/Date

General description of ordering code

01/16

04/10/16

Series	n. poles	pitch	version	color	custom
MRM6	1÷24	-5/5.08	-V		

UNITS:mm SIZE: A4



Series:

MRM6-5/5.08-V