

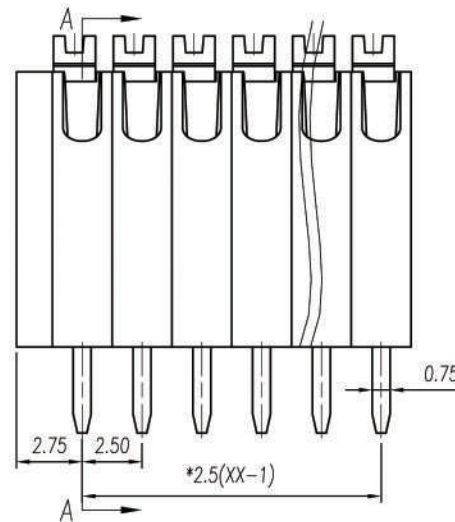

CÉLION

product specification

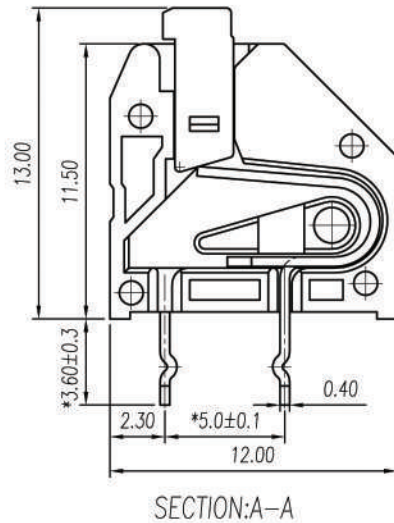
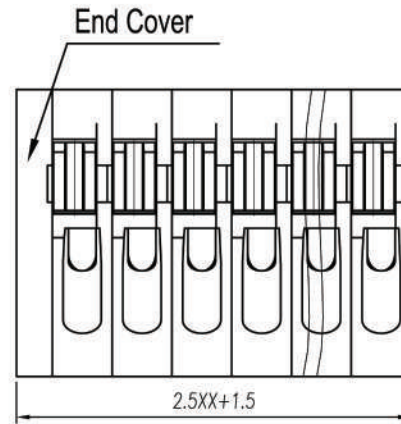
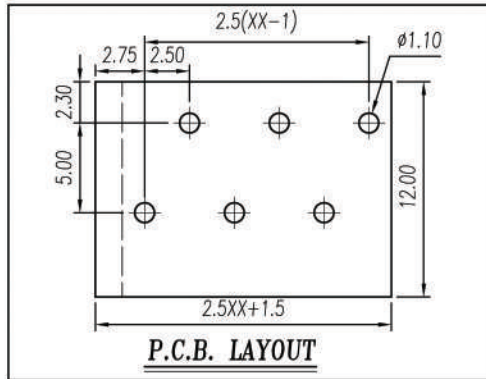

Approvals

UL-cUL not approved
VDE not approved

Electrical

Standard
Rated voltage 300V
Rated current 4A
Contact resistance 20mΩ
Insulation resistance 500MΩ/DC500V
Withstanding voltage AC 2000V/ 1 Min
Wire range 28-20 AWG 0,5 sqmm

Torque
Temp. Range -40°C - +105°C
Stripping length 9-10 mm
Max sold. time +250°C for 5 sec.

Dimensions

Pitch 2.5 mm
Poles 1-xx

Material

Housing PA66 UL94 V0
Pin Phosphore bronze
Clamp

Version/Version Data/Date

2014/1 03/06/14

General description of ordering code

Series	n. poles	pitch	version	color	custom
MRM1	1-xx	2.5	V1		

UNITS:mm SIZE: A4

CELION SAS - GRIGNY (FRANCE)

Series:

MRM1-2.5-V1