

p.c.b layout

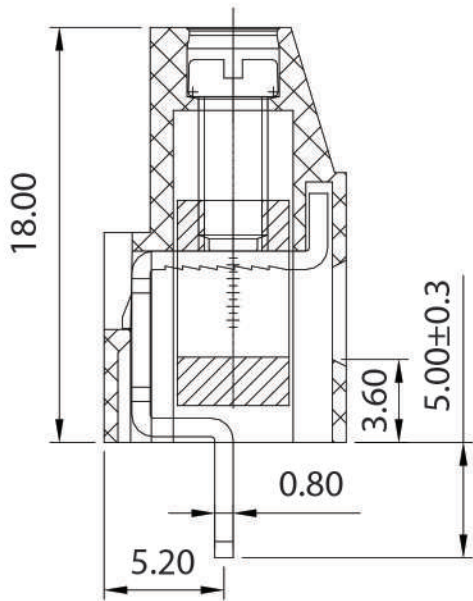

SECTION: A-A

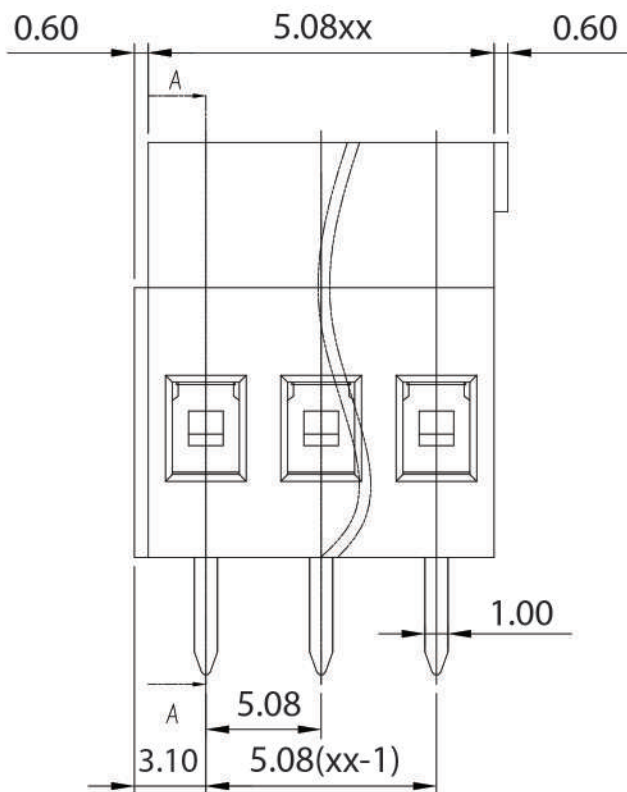
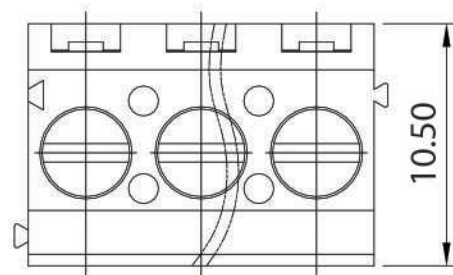

Approvals



16A-300V
20A-250V

Electrical

Rated voltage 250V
Rated current 25A
Contact resistance 20mΩ
Insulation resistance 500MΩ/DC500V
Withstanding voltage AC2000V/1min
Wire range 26-12 AWG 2,5mm²

Torque 0,5Nm (4.5Lb in)
Temp. Range -40°C +105°C
Stripping lenght 7 mm
Max sold. time +250°C for 5 sec

Dimensions

Pitch 5,08 mm
Poles 2÷24

Material

Housing PA66 UL94V0
Pin Copper Alloy, Sn plated
Cage Copper Alloy, Ni plated
Screws M3 steel, Zn plated
Side Block
Nut screw
Clamp

General description of ordering code

Series	n. Poles	Pitch	Version	Color	Custom
MRA52	2÷24	-5.08	-V		

Version Date

2020/01 29/10/2020



linear dimension (Tolerances Standard GB/T 14486-2008)

variable range	to 6	over 6 to 10	over 10 to 30	over 30 to 60	over 60 to 100	over 100 to 160	over 160 to	to 10	over 10 to 100	over 100 to
tolerance	±0.20	±0.30	±0.50	±0.70	±1.00	±1.30	±1.60	0.10	0.30	0.60

UNITS: mm

SCALE: 10:1

SHEET SIZE: ISO A4



MRA52-5.08-V