

SECTION A-A  
P. C. B. LAYOUT

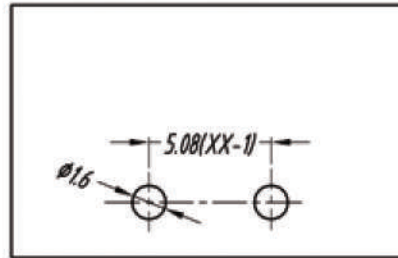
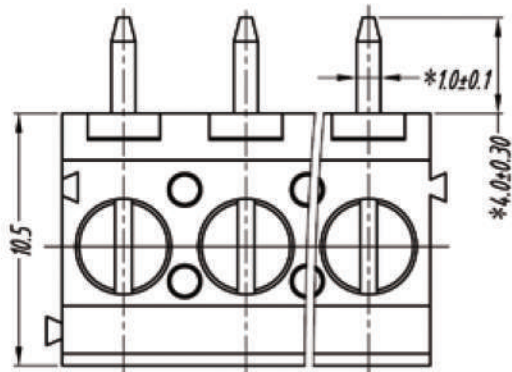

TOLERANCES EXCEPT AS NOTED

### Electrical

Standard: UL-IEC  
 Rated voltage: 300V-250V  
 Rated current: 25A-20A  
 Wire range: 24-12AWG-2.5mm<sup>2</sup>  
 Withstanding voltage: AC2000V/1Min

### Mechanical

Torque: 0.5Nm (4.5Lb'in)  
 Temp.Range: -40°C~+105°C  
 Strip length: 6-7mm



### Dimensions

Pitch: 5.08mm (0.200")  
 Poles: 2p-xxp

### Material

Housing: PA66, UL94V-0  
 Screws: M3, steel, Zinc plated  
 Pin header: Brass, Tin plated  
 Wire guard: Brass, Ni plated

variable range	linear dimension				fillet	chamfer	short angle sid			≡	-	□	//	⊥		
	to 6	over 6 to 30	over 30 to 120	over 120 to 480	all to 6	over 6 to 10	over 10 to 30'	over 30' to 120'	over 120' to 10'							
tolerance	±0.1	±0.2	±0.3	±0.5	±0.2	±0.5	±1	1'	30'	20'	10'	0.5	0.025	0.06	0.12	0.4

UNITS	mm	SIZE	A4	SCALE	FIRST ANGLE PROJECTION	
						
					NAME	MRA52-5.08-H