

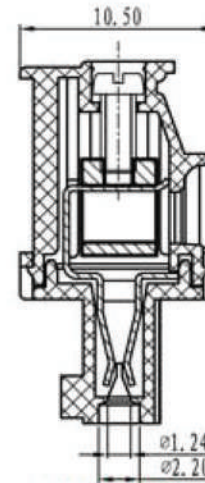

# CÉLION

product specification

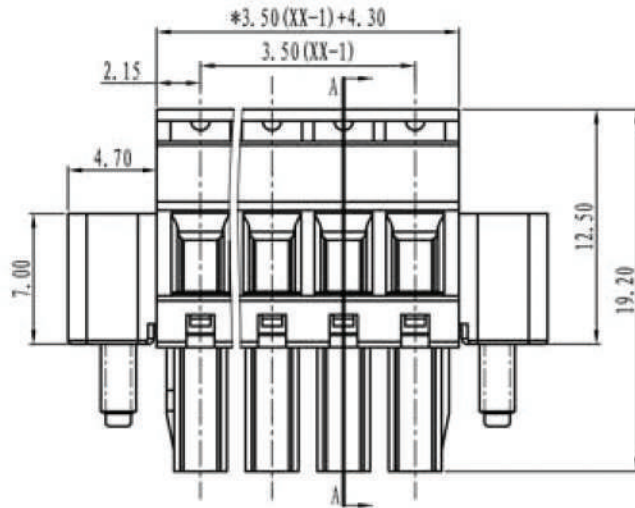

SECTION A-A

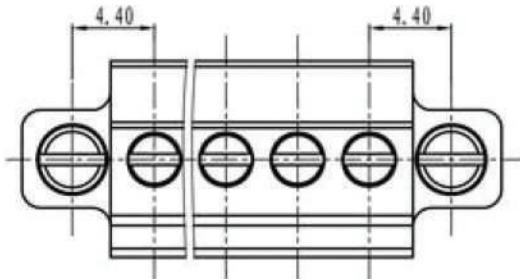

TOLERANCES EXCEPT AS NOTED

variable range	linear dimension				fillet	chamfer	short angle sid				≡	-	□	//	⊥	
	to	over	to	over			to	to	to	to						to
6	6	30	120	480	all	to 6	to 10	to 10	to 10	to 10	to 10	to 10	to 10	to 10	to 10	to 10
±0.1	±0.2	±0.3	±0.5	±0.9	±0.2	±0.5	±1	1°	30'	20'	10'	0.5	0.025	0.06	0.12	0.4

### Electrical

Standard: UL-IEC  
 Rated voltage: 300V-250V  
 Rated current: 8A-7A  
 Contact resistance: 20m Ω  
 Wire range: 28-16AWG 1.5mm<sup>2</sup>  
 Withstanding voltage: AC2000V/1Min  
 Insulation resistance: 5000M Ω/DC1000V

### Mechanical

Temp.Range: -40°C~+105°C  
 Torque: 0.2Nm (1.7lb'in)  
 Strip length: 6-7mm

### Dimensions

Pitch: 3.50mm  
 Poles: 2p-24p

### Material

Housing: PA66, UL94V-0  
 Screws: M2, steel Zinc plated  
 Wire guard: Brass, Ni plated  
 Clamp: Phospor bronze, Ni plated

Schema generale del codice di ordinazione / General description of ordering code

serie	n°poli	passo	versione	colore	custom
CRV	02/22	3.5	LF		

UNITS	mm	SIZE	A4	SCALE	FIRST ANGLE PROJECTION	
					NAME	CRV-3.5-LF