

SECTION: A-A

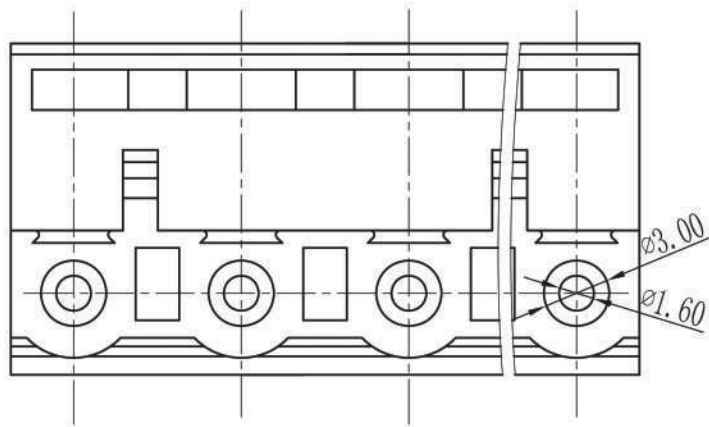

Approvals



15A-300V
10A-400V

Electrical

Rated voltage 450V
Rated current 20A
Contact resistance 20mΩ
Insulation resistance 500MΩ/DC500V
Withstanding voltage AC2000V/1min
Wire range 22-12 AWG 2,5mm²

Torque 0,5Nm (4.5Lb in)
Temp. Range -40°C +105°C
Stripping length 7 mm
Max sold. time

Dimensions

Pitch 7,62 mm
Poles 2÷24

Material

Housing PA66 UL94V0
Pin
Cage Copper Alloy, Ni plated
Screws M3 steel, Zn plated
Side Block
Nut screw
Clamp Phosphore bronze, Ni plated

General description of ordering code

Series	n. Poles	Pitch	Version	Color	Custom
CRF	02÷24	-7.62			

Version Date

2020/01 10/06/2020

variable range	to 6	over 6 to 10	over 10 to 30	over 30 to 60	over 60 to 100	over 100 to 160	over 160 to	to 10	over 10 to 100	over 100 to
tolerance	±0.20	±0.30	±0.50	±0.70	±1.00	±1.30	±1.60	0.10	0.30	0.60