

**P.C.B. LAYOUT**

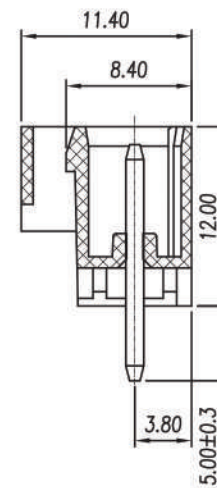

**Approvals**

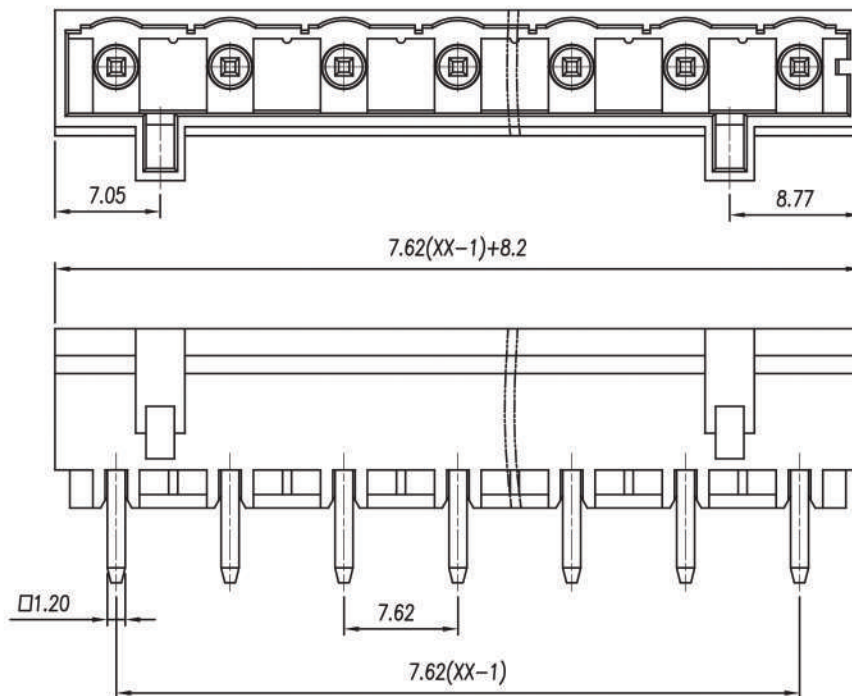

15A-300V  
not approved

**Electrical**

Rated voltage 250v  
Rated current 16A  
Contact resistance 20Ω  
Insulation resistance 500MΩ/DC500V  
Withstanding voltage AC2000V/1 min  
Wire range ---

Torque ---  
Temp. Range -40°C + 105°C  
Stripping length ---  
Max sold. time +250°C for 5 sec.

**Dimensions**

Pitch 7.62  
Poles 2÷24

**Material**

Housing PA66 UL94V0  
Pin ---  
Cage ---  
Screws ---  
Side Block ---  
Nut screw Copper alloy, Tin plated  
Clamp ---

**General description of ordering code**

Series	n. Poles	Pitch	Version	Color	Custom
CMP2	02÷24	-7.62	-VP		-S

**Version** 18/01  
**Date** 05/02/18



**UNITS:** mm

**SHEET SIZE:** ISO A4

**SCALE:** 2.5:1

> 0 ~ 3

> 3 ~ 18

> 18 ~ 50

> 50 ~ 120

± 0.12

± 0.15

± 0.3

± 0.5



**CMP2-7.62-VP-S**