

P.C.B. LAYOUT

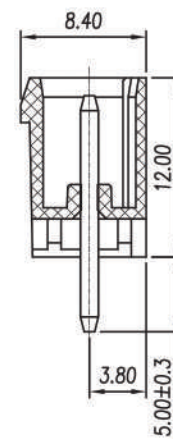

Approvals

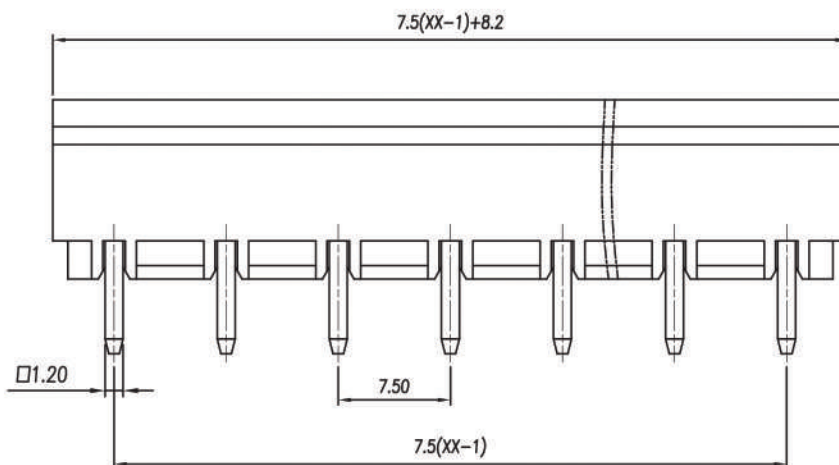
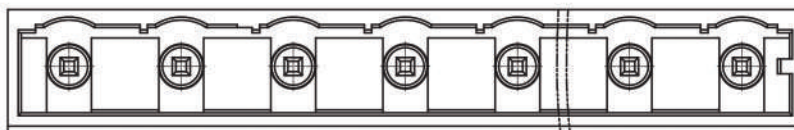

15A-300V
not approved

Electrical

Rated voltage 250v
Rated current 16A
Contact resistance 20Ω
Insulation resistance 500MΩ/DC500V
Withstanding voltage AC2000V/1 min
Wire range ---

Torque ---
Temp. Range -40°C + 105°C
Stripping length ---
Max sold. time +250°C for 5 sec.

Dimensions

Pitch 7,5 mm
Poles 2÷24

Material

Housing PA66 UL94V0
Pin ---
Cage ---
Screws ---
Side Block ---
Nut screw Copper alloy, Tin plated
Clamp ---

General description of ordering code

Series	n. Poles	Pitch	Version	Color	Custom
CMP2	02÷24	-7.5	-VP		

Version 18/01
Date 07/02/18



UNITS: mm

SHEET SIZE: ISO A4

SCALE: 2.5:1

> 0 ~ 3

> 3 ~ 18

> 18 ~ 50

> 50 ~ 120

± 0.12

± 0.15

± 0.3

± 0.5



CMP2-7.5-VP