

p.c.b. layout

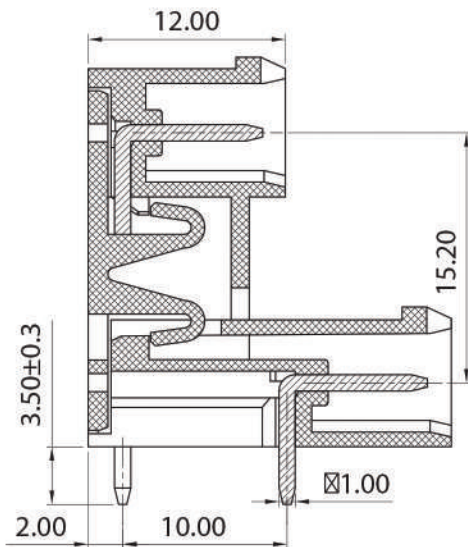

Section: A-A

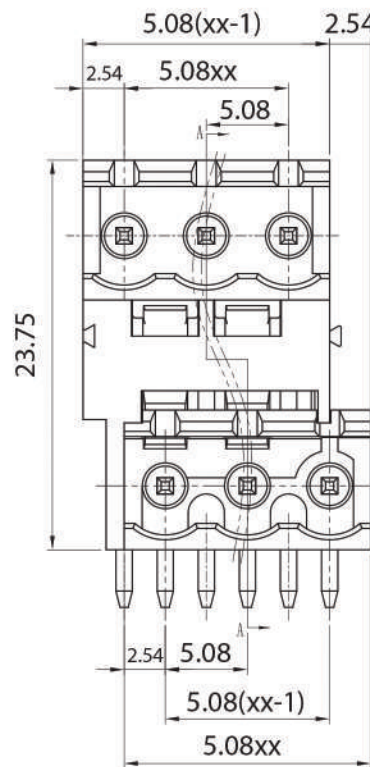
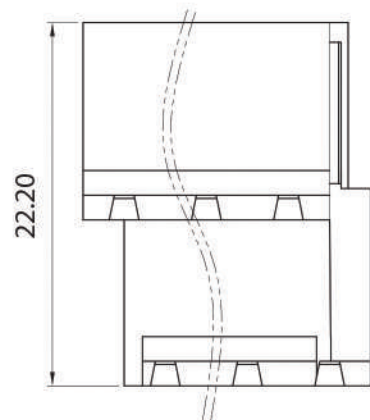

**Approvals**



15A-300V

**Electrical**

Rated voltage 320V  
 Rated current 10A  
 Contact resistance 20mΩ  
 Insulation resistance 500MΩ/DC500V  
 Withstanding voltage AC1600V1 min  
 Wire range

Torque  
 Temp. Range -40°C+105°C  
 Stripping lenght  
 Max sold. time +250°C for 5 sec

**Dimensions**

Pitch 5.08 mm  
 Poles 2+2+3+3

**Material**

Housing PA66 UL94V0  
 Pin Copper Alloy, tin plated  
 Cage  
 Screws  
 Side Block  
 Nut screw  
 Clamp

**General description of ordering code**

Series	n. Poles	Pitch	Version	Color	Custom
CMD	02+24	-5.08	-H		

**Version Date**

21/01 21/04/2021



UNITS: mm

SHEET SIZE: ISO A4

SCALE: 10:1

> 0 ~ 3

> 3 ~ 18

> 18 ~ 50

> 50 ~ 120

± 0.12

± 0.15

± 0.3

± 0.5



**CMD-5.08-H**