

P.C.B. LAYOUT

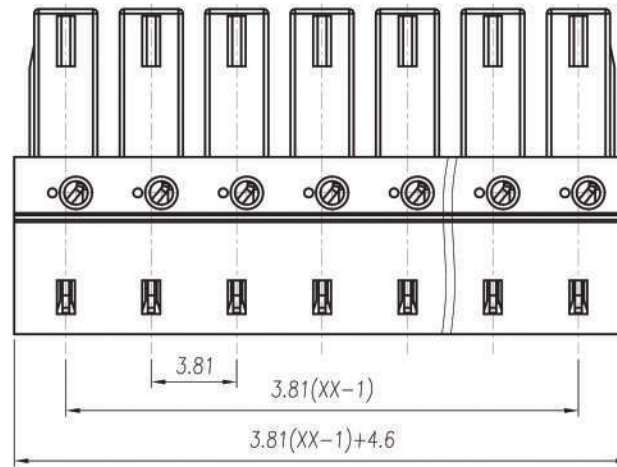

Approvals

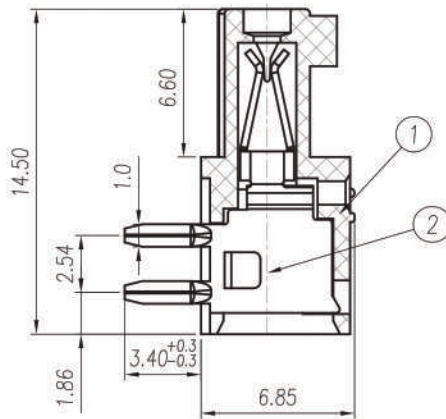
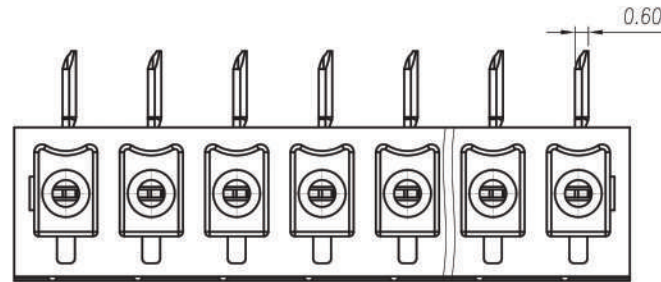

8A-300V
not approved

Electrical

Rated voltage 250V
Rated current 10A
Contact resistance 20mΩ
Insulation resistance 500MΩ/DC500V
Withstanding voltage AC2000V/1 min
Wire range

Torque
Temp. Range -40°C+105°C
Stripping length
Max sold. time +250°C for 5 sec

Dimensions

Pitch 3,81 mm
Poles 2÷24

Material

Housing PA66 UL94V0
Pin Copper Alloy, Sn plated
Cage
Screws
Side Block
Nut screw
Clamp

General description of ordering code

Series	n. Poles	Pitch	Version	Color	Custom
CMA	02÷24	-3.81	-H		

Version 18/01
Date 05/03/18



UNITS: mm

SHEET SIZE: ISO A4

SCALE: 10:1

> 0 ~ 3

> 3 ~ 18

> 18 ~ 50

> 50 ~ 120

± 0.12

± 0.15

± 0.3

± 0.5



CMA-3.81-H