

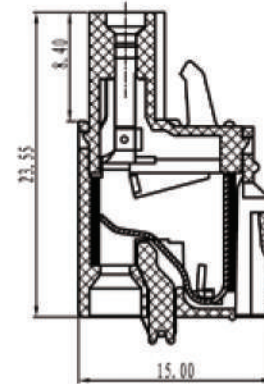

CÉLION

product specification

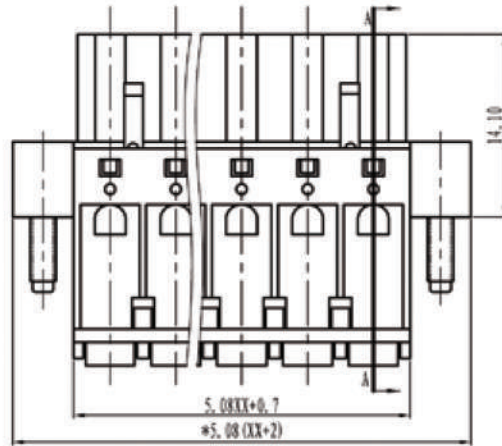

SECTION A-A

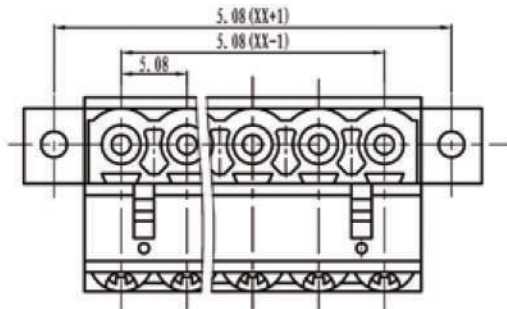

TOLERANCES EXCEPT AS NOTED

variable range	linear dimension				fillet	chamfer		∠ short angle sid				≡	-	□	//	⊥
	to 6	over 6 to 30	over 30 to 120	over 120 to 480	all	to 6	over 6 to 10	over 10 to 30'	over 30' to 50'	over 50' to 120'	over 120' to 10'	all	to 5	over 5 to 30	over 30 to 120	over 120 to 0.4
tolerance	±0.1	±0.2	±0.3	±0.5	±0.2	±0.5	±1	1'	30'	20'	10'	0.5	0.025	0.06	0.12	0.4

Electrical

Standard: UL-IEC
 Rated voltage: 300V-320V
 Rated current: 10A-20A
 Contact resistance: 20m Ω
 Wire range: 28-16AWG-1.5mm²
 Withstanding voltage: AC2000V/1Min
 Insulation resistance: 5000M Ω/DC1000V

Mechanical

Temp.Range: -40°C~+105°C
 Strip length: 7-8mm

Dimensions

Pitch: 5.08mm
 Poles: 2p-24p

Material

Housing: PA66, UL94V-0
 Screws: M2, steel Zinc plated
 Clamp: Phosphor bronze, Ni plated

UNITS	mm	SIZE	A4	SCALE	FIRST ANGLE PROJECTION	
					NAME	CFS-5.08-F