

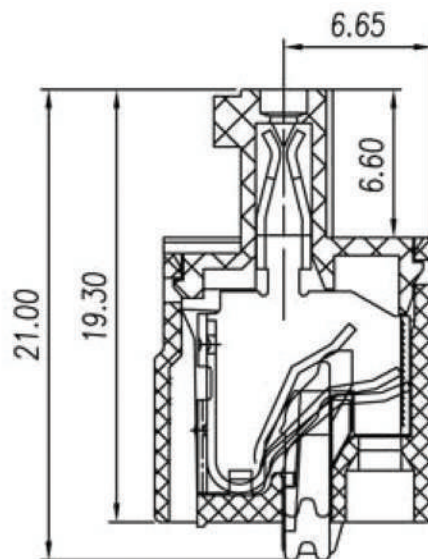

# CÉLION

product specification

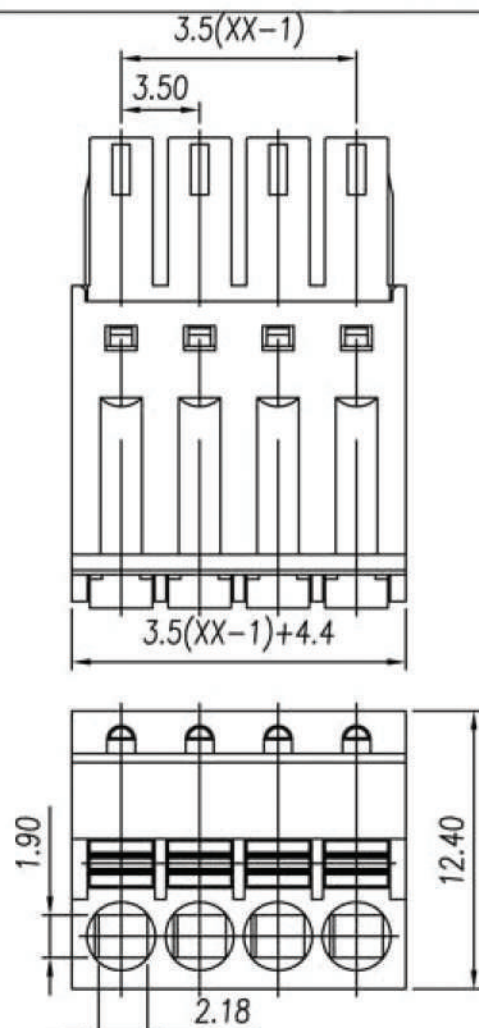

Electrical		
Standard	UL	IEC
Rated voltage	300V	250V
Rated current	8A	13,5A
Contact resistance	20mΩ	
Insulation resistance	500MΩ/DC500V	
Withstanding voltage	AC2000V/1 Min	
Wire range	28-16 AWG 1.5sqmm	

Mechanical	
Temp. Range	-40°C + 105°C
Max soldering temp.	+250°C for 5 sec

Dimensions	
Pitch	3.5 mm
Poles	2+24

Material	
Housing	PA66, UL94V0
Clamp 1	Phosphore Bronze, Nikel plated
Clamp 2	Stainless Steel
Screws	M2.5 Steel Zinc plated

Schema generale del codice di ordinazione/General description of ordering code

Series	n. poles	pitch	version	color	custom
CFS	02+24	3.5			

linear dimension (Tolerances Standard GB/T 14486-2008)											≡	-	□	//	⊥	
variable range	to 6	over 6 to 10	over 10 to 18	over 18 to 30	over 30 to 50	over 50 to 80	over 80 to 120	over 120 to 160	over 160 to 200	over 200 to 250	over 250 to	all	to 5	over 5 to 30	over 30 to 120	over 120 to
tolerance	±0.1	±0.14	±0.19	±0.25	±0.32	±0.43	±0.57	±0.72	±0.88	±1.05	±1.25	0.5	0.025	0.06	0.12	0.4

UNITS	mm	SIZE	A4	SCALE	3:1	THIRD ANGLE PROJECTION
						CFS-3.5