

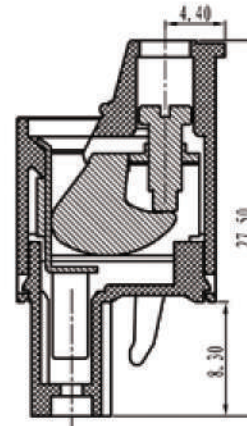

CÉLION

product specification

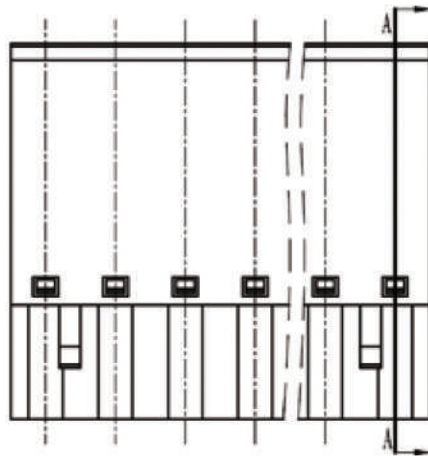

SECTION A-A

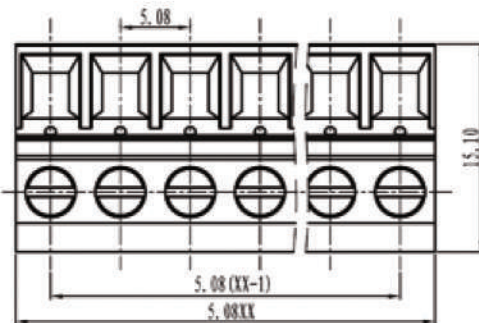

TOLERANCES EXCEPT AS NOTED

Electrical

Standard: UL-IEC
 Rated voltage: 250V-320V
 Rated current: 12A-20A
 Contact resistance: 20m Ω
 Wire range: 28-12AWG-2.5mm²
 Withstanding voltage: AC2000V/1Min
 Insulation resistance: 5000M Ω/DC1000V

Mechanical

Torque: 0.4Nm (3.6Lb'in)
 Temp.Range: -40°C~+105°C
 Strip length: 7-8mm

Dimensions

Pitch: 5.08mm
 Poles: 2p-24p

Material

Housing: PA66, UL94V-0
 Screws: M2.5, steel Zinc plated
 Wire guard: Phosphor bronze, Ni plated
 Clamp: Phosphor bronze

| variable range | linear dimension | | | | | fillet | chamfer | short angle sid | | | ≡ | - | □ | // | ⊥ | | |
|----------------|------------------|--------------|----------------|-----------------|-------------|--------|---------|-----------------|---------------|----------------|-----|------|--------------|----------------|-------------|------|-----|
| | to 6 | over 6 to 30 | over 30 to 120 | over 120 to 480 | over 480 to | all | to 6 | over 6 to 10 | over 10 to 50 | over 50 to 120 | all | to 5 | over 5 to 30 | over 30 to 120 | over 120 to | | |
| tolerance | ±0.1 | ±0.2 | ±0.3 | ±0.5 | ±0.9 | ±0.2 | ±0.5 | ±1 | 1' | 30' | 20' | 10' | 0.5 | 0.025 | 0.06 | 0.12 | 0.4 |

| UNITS | mm | SIZE | A4 | SCALE | FIRST ANGLE PROJECTION | |
|-------|----|------|----|-------|------------------------|----------|
| | | | | | | |
| | | | | | NAME | CFF-5.08 |