

SECTION: A-A

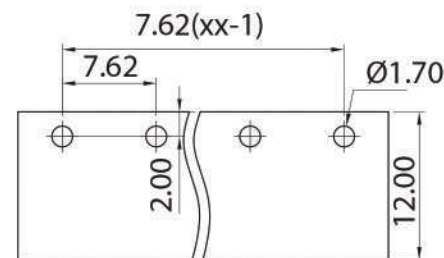

p.c.b. layout

**Approvals**

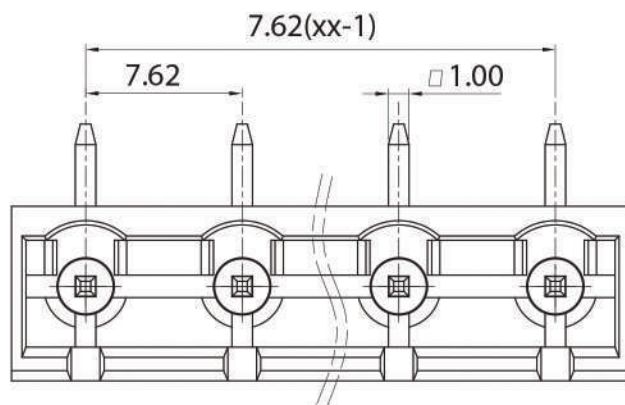

15A-300V  
10A-400V

**Electrical**

Rated voltage 450V  
Rated current 20A  
Contact resistance 20mΩ  
Insulation resistance 500MΩ/DC500V  
Withstanding voltage AC2000V/1min  
Wire range

Torque  
Temp. Range -40°C +105°C  
Stripping length  
Max sold. time +250°C for 5 sec

**Dimensions**

Pitch 7.62 mm  
Poles 2÷24

**Material**

Housing PA66 UL94V0  
Pin Copper Alloy, Sn plated  
Cage  
Screws  
Side Block  
Nut screw  
Clamp

**General description of ordering code**

Series	n. Poles	Pitch	Version	Color	Custom
CCM	02÷24	-7.62	-CH		

**Version Date**

2020/01 10/06/2020

variable range	to 6	over 6 to 10	over 10 to 30	over 30 to 60	over 60 to 100	over 100 to 160	over 160 to	to 10	over 10 to 100	over 100 to
tolerance	±0.20	±0.30	±0.50	±0.70	±1.00	±1.30	±1.60	0.10	0.30	0.60