

p.c.b. layout

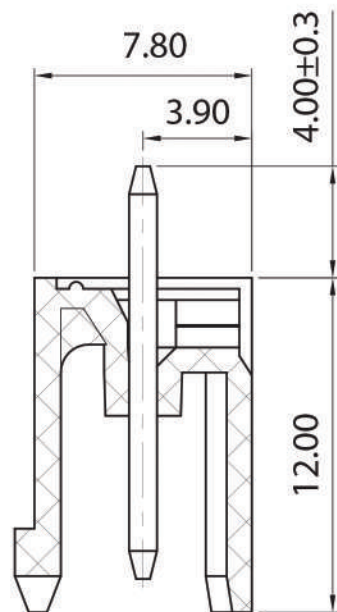

SECTION: A-A

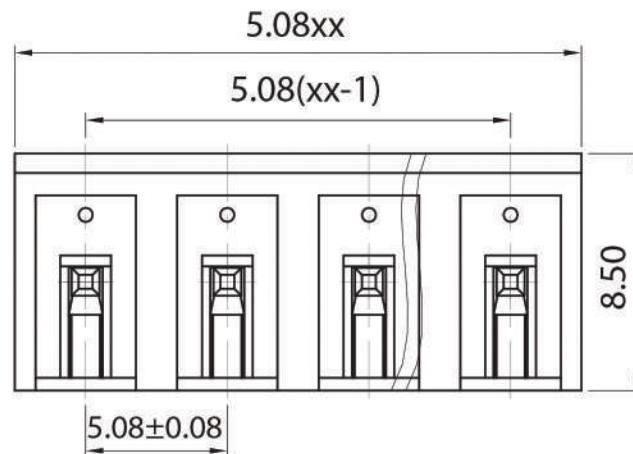
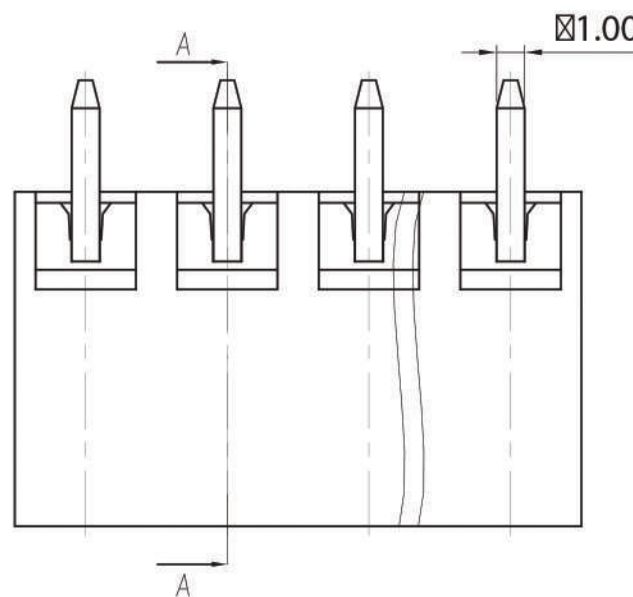

**Approvals**



15A-300V  
10A-320V

**Electrical**

Rated voltage 320V  
Rated current 20A  
Contact resistance 20mΩ  
Insulation resistance 500MΩ/DC500V  
Withstanding voltage AC2000V1 min  
Wire range

Torque  
Temp. Range -40°C+105°C  
Stripping length  
Max sold. time +250°C for 5 sec

**Dimensions**

Pitch 5.08 mm  
Poles 2÷24

**Material**

Housing PA66 UL94V0  
Pin Copper Alloy, tin plated  
Cage  
Screws  
Side Block  
Nut screw  
Clamp

**General description of ordering code**

Series	n. Poles	Pitch	Version	Color	Custom
CCM	02÷24	-5.08	-V		

**Version Date**

21/01 26/02/2021