

p.c.b. layout

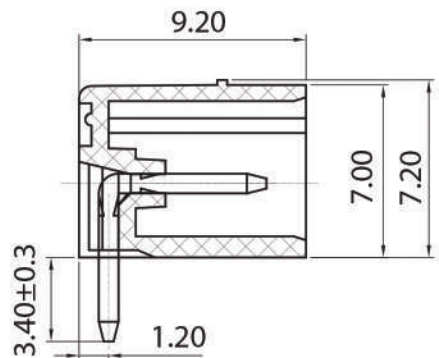

section: A-A

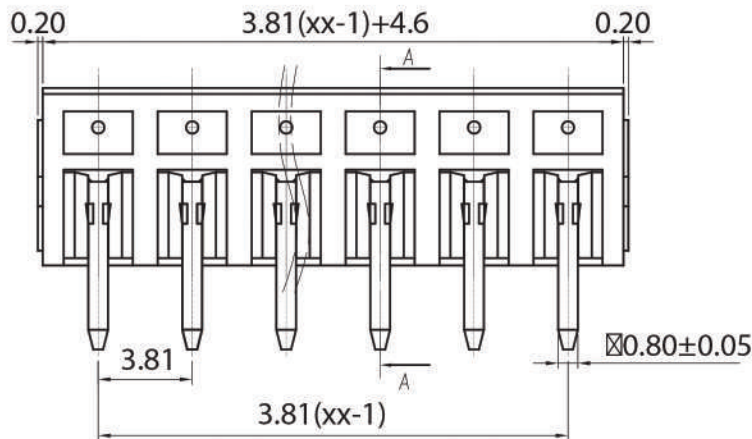
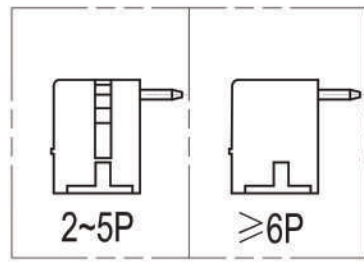
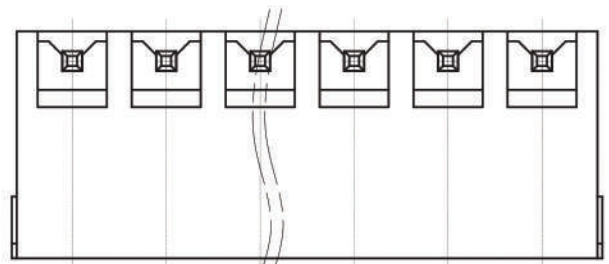

Approvals



8 A-300V
7 A-250V

Electrical

Rated voltage 250V
Rated current 7A
Contact resistance 20mΩ
Insulation resistance 500MΩ/DC500V
Withstanding voltage AC1600V1 min
Wire range

Torque
Temp. Range -40°C+105°C
Stripping length
Max sold. time +250°C for 5 sec

Dimensions

Pitch 3.81
Poles 2÷24

Material

Housing PA66 UL94V0
Pin Copper Alloy, tin plated
Cage
Screws
Side Block
Nut screw
Clamp

General description of ordering code

Series	n. Poles	Pitch	Version	Color	Custom
CCM	02÷24	-3.81	-CH		

Version 21/01 **Date** 27/04/2021



UNITS: mm		SHEET SIZE: ISO A4		SCALE: 10:1	
> 0 ~ 3	> 3 ~ 18	> 18 ~ 50	> 50 ~ 120		
± 0.12	± 0.15	± 0.3	± 0.5		



CCM-3.81-CH