

p.c.b. layout

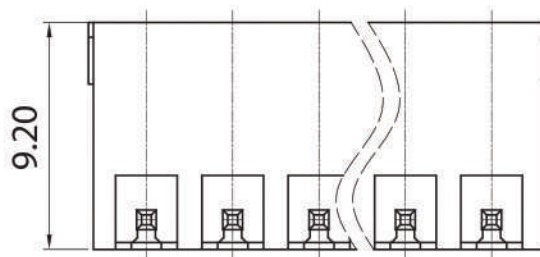

Approvals

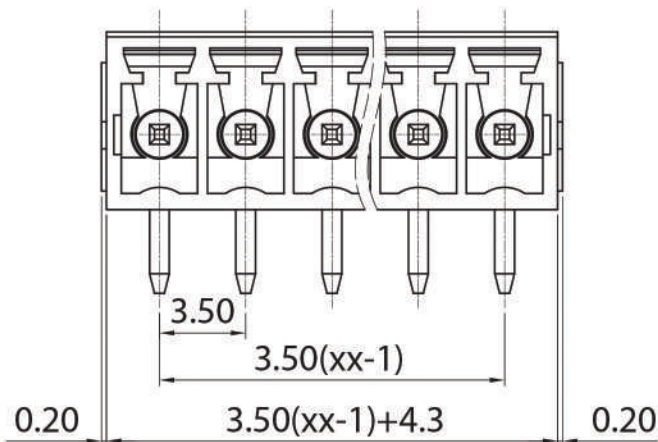
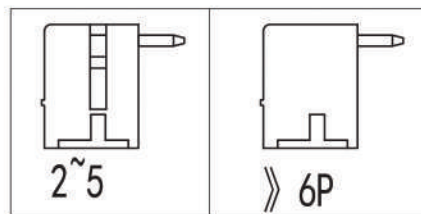
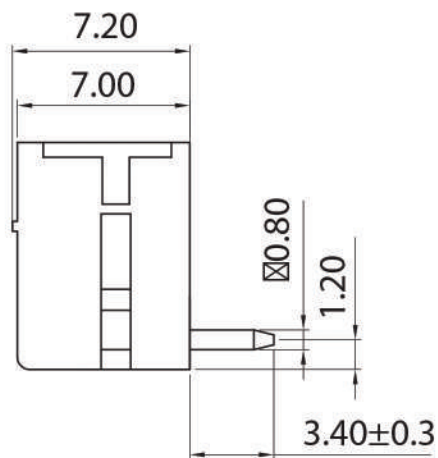

8A-300V
7A-250V

Electrical

Rated voltage 250V
Rated current 7A
Contact resistance 20mΩ
Insulation resistance 500MΩ/DC500V
Withstanding voltage AC1600V1 min
Wire range

Torque
Temp. Range -40°C+105°C
Stripping length
Max sold. time +250°C for 5 sec

Dimensions

Pitch 3,5 mm
Poles 2÷24

Material

Housing PA66 UL94V0
Pin Copper Alloy, tin plated
Cage
Screws
Side Block
Nut screw
Clamp

General description of ordering code

Series	n. Poles	Pitch	Version	Color	Custom
CCM	02÷24	-3.5	-CH		

Version Date

21/01 20/05/2021