

p.c.b. layout

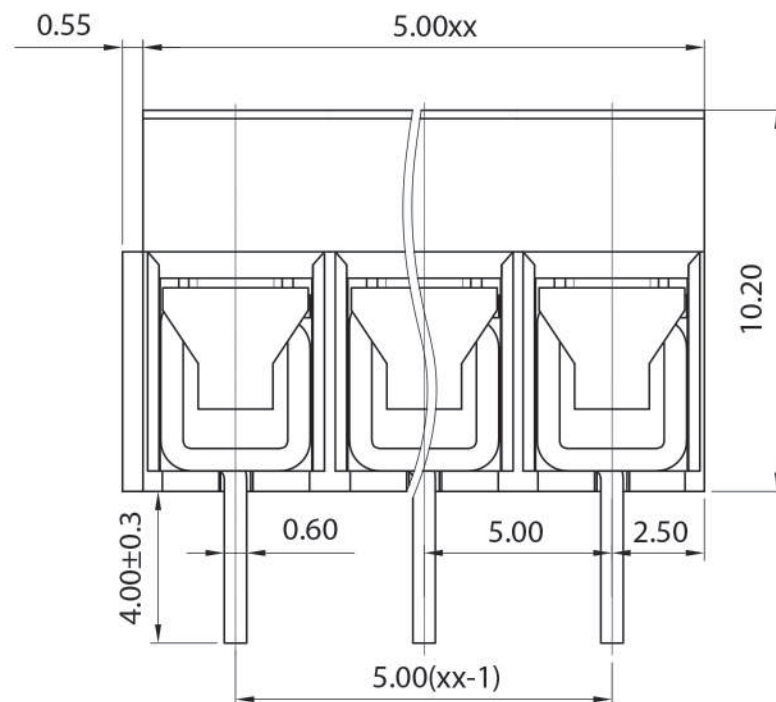

### Approvals

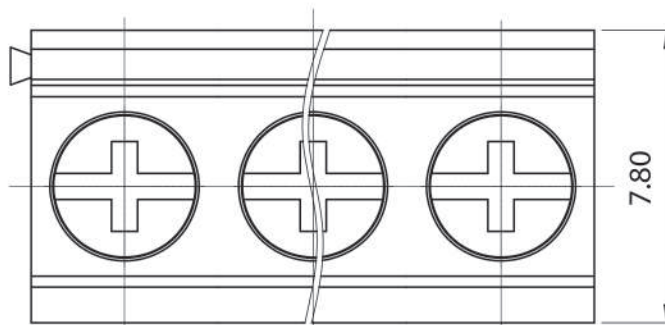
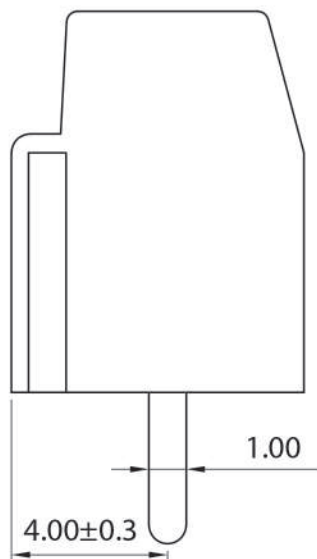

8A- 300V

not approved

### Electrical

Rated voltage	250V
Rated current	18A
Contact resistance	20mΩ
Insulation resistance	500MΩ/DC500V
Impulse voltage	1.6KV
Wire range	1,5mm2 22÷16 AWG

Torque	0,4Nm (3.6Lb In)
Temp. Range	-40°C + 105°C
Stripping length	5 mm
Max sold. time	+250°C for 5 sec.

### Dimensions

Pitch	5 mm
Poles	2÷24

### Material

Housing	PA66 UL94V0
Pin	Copper Alloy, Sn plated
Cage	Copper Alloy, Ni plated
Screws	M2.5; Steel Zn plated
Side Block	---
Nut screw	---
Clamp	---

### General description of ordering code

Series	n. Poles	Pitch	Version	Color	Custom
BLR51	2÷24	-5	-V		

### Version Date

2020/01

06/04/2020